

OWNER'S MANUAL
LOCK-N-LOAD®
CASE
FEEDER

Instructional and troubleshooting videos for this product are available on the Hornady website.

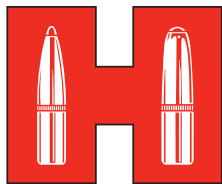

Hornady
Accurate. Deadly. Dependable.



Table of Contents

ASSEMBLY Page 2

CHANGE-OVERS Page 12

The Hornady® Lock-N-Load® Case Feeder is capable of feeding both pistol and rifle cases. When changing cartridges refer to this section.

- Feed Plate
- Feed Tube
- Pivot Adapter/Pivot Adapter Bushing
- Drop Tube
- V-Block
- Adjustments
 - Case Feed Door Adjustment*

TROUBLE SHOOTING Page 14

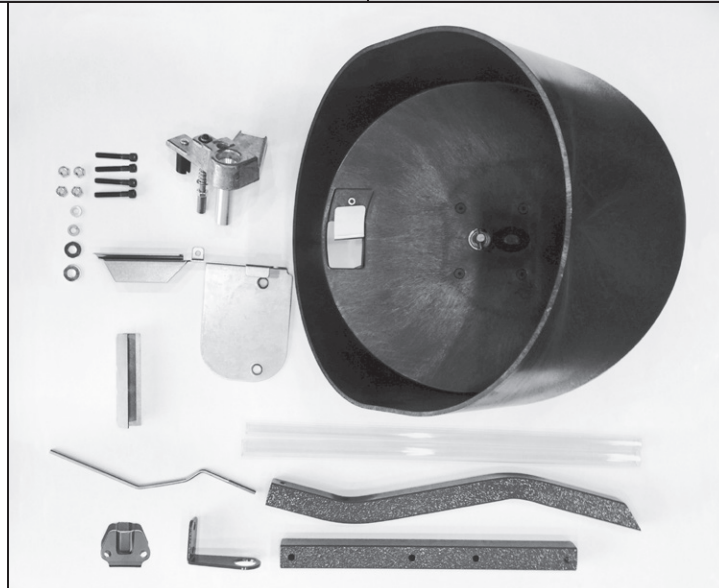
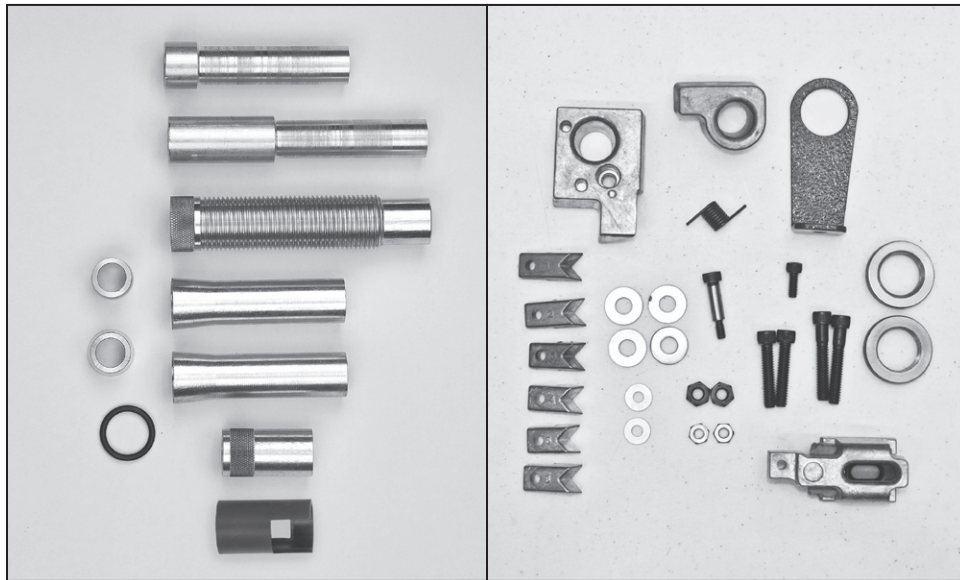

See pages 3-4 for Parts List

LOCK-N-LOAD® AP™ CASE FEEDER

OVERVIEW

Your new AP™ Case Feeder has been packaged to insure minimal vibration and damage during transportation.

Remove all the parts from the packing box (see page 1) and spread them out over a large flat surface. **Refer to the Lock-N-Load® Case Feeder parts list and exploded view on the next two pages** to make sure all necessary parts are identified.

The manual provides step-by-step instructions and suggestions that make set-up and operation easy and understandable.

NOTE: Everything is designed and machined to fit easily together without modification. If you find that it is necessary to force parts together, stop and check the instructions and illustrations we have provided.

List of needed hand tools:

- 3/8" wrench
- 7/16" wrench
- 9/16" wrench
- 1/8" Allen wrench
- 5/32" Allen wrench
- 3/16" Allen wrench
- Pliers or vise grips
- Small hammer

- 1 If your AP™ press has a cartridge box bracket that mounts on top of the press, it will need to be changed out for the Main Bracket (42). To do this, unbolt the press from the bench top, remove the old cartridge box bracket, and slide the new Main Bracket under the press so the two raised holes fit into the press mounting holes (see exploded view for correct orientation). Re-mount the press to the bench top using the same hardware that was previously used to bolt the press down.

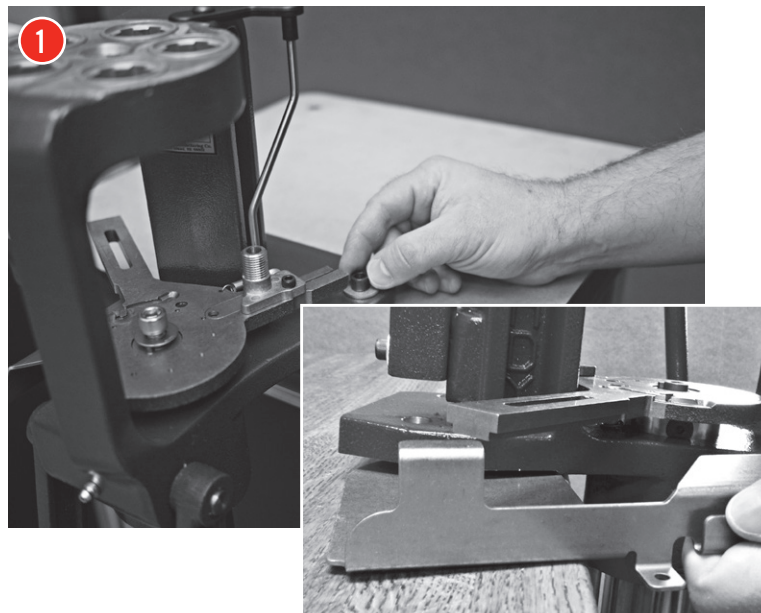

Assembling the 2-pc Square Tubing.

- 2 Place Lower Case Feeder Stand next to mounting holes on the back of the AP™ press to determine proper orientation of the Lower Case Feeder Stand. Once the "top" of the Lower Case Feeder Stand has been determined, place the Lower Case Feeder Stand onto a block of scrap wood. Next insert the Tube Connector into the Lower Case Feeder Stand until the holes align. Place the Feed Tube Mounting Bracket onto the Lower Case Feeder Stand so the Feed Tube Mounting bracket is on the open end of the Tube Connector (see photo). Place a 1/4-20 x 1.5" bolt through the Feed Tube Mounting bracket and Lower Case Feeder Stand and loosely attach the flat washer, lock washer, and nut.

Place Upper Case Feeder Stand over the Tube Connector until it touches the Lower Case Feeder Stand. Place a 1/4-20 x 1.5" bolt through the Feed Tube Mounting bracket and Upper Case Feeder Stand and securely attach the flat washer, lock washer, and nut. Tighten the lower nut in the Lower Case Feeder Stand.

Attach assembly onto AP™ Press.

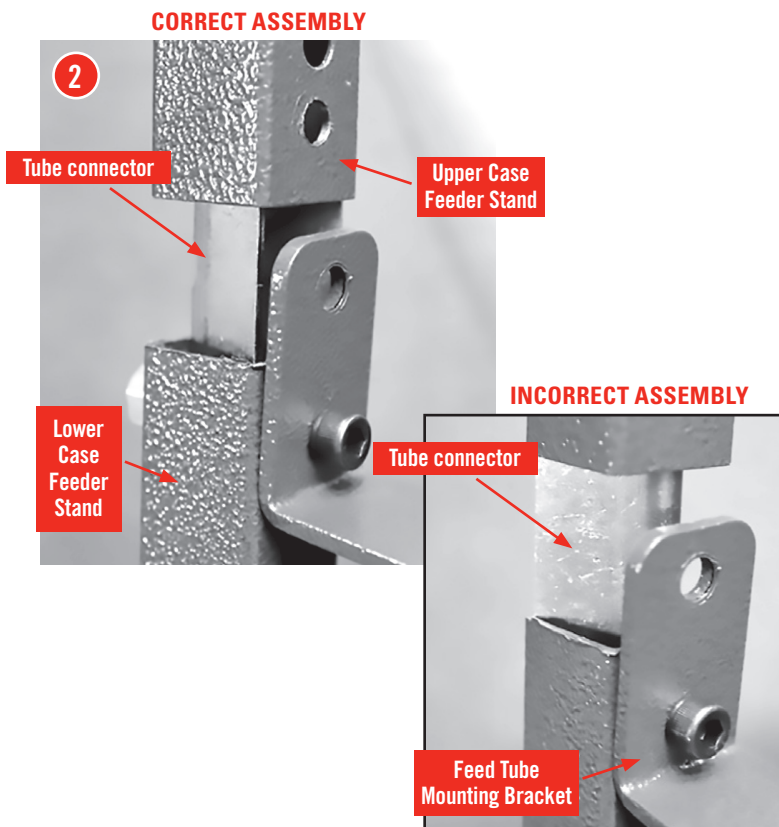

LOCK-N-LOAD® AUTO PROGRESSIVE (AP™) CASE FEEDER

PARTS LIST

Item No.	Production Part No.	Qty.	Description
1	398441	1	Case Feed Bowl
2	398313	4	10-32 x ¾ FHSCS
4	398445	4	8-32 x ¾ Screw
5	398443	1	Case Feed Funnel Front
6	398375	2	4-40 Hex Head Lock Nut
7	399630	1	Micro Switch
8	398442	1	Case Feed Funnel Back
9	398376	2	4-40 x 5/8 BHSCS
10	398332	1	Rocker Switch
11	398331	1	Motor
12	398444	1	Motor Cover
13	398320	1	Feed Tube - Large
14	398321	1	Feed Tube - Small
15	398303	1	Feed Tube End Primary
16	398446	1	Feed Tube Mounting Bracket
17	396440	2	Lock Ring
18	398298	1	Pivot Extension
19	398290	1	Pivot
20	398310	1	1/4 - 3/4 Shoulder Bolt
21	398311	1	3/0 x 3/4 Taper Pin
22	398305	1	Drop Tube - Large
23	398288	1	Spring, Torsion
24	398317	1	Push Rod
25	398371	1	Push Rod Tip
26	390178	6	1/4-20 Hex Head Nut
27	398349	1	Push Rod Bushing
28	398364	1	10 x 1/2 Sheet Metal Screw Pan Head Phillips
29	398344	1	Pivot Body
30	398363	1	Push Rod Spring
31	398343	1	Cam Wire Support
32	398425	1	E Clip 1/4
34	398372	1	Push Rod Lower
37	398285	1	Case Feed Door Adjustment
38	398291	1	Case Slide
39	398307	1	Case Slide Rod Guide
40	398308	1	Case Slide Rod Guide Spring

Item No.	Production Part No.	Qty.	Description
41	392011	2	10-32 Hex Head Nut
42	398289	1	Main Bracket
43	398299	1	Cam Wire
47	398312	2	1/4-20 x 1.25 SHCS
48	390128	4	1/4 Flat Washer Zinc Plated
49	392031	2	1/4" Lock Washer
50	398360	1	Feed Tube Insert - Small
51	398300	1	Pivot Adapter Bushing
52	398301	1	Pivot Bushing
53	398306	1	Drop Tube-Small
54	095310	*	Case Feed Plate - Small Pistol
55	095312	*	Case Feed Plate - Large Pistol
56	095314	*	Case Feed Plate - Small Rifle
57	095316	*	Case Feed Plate - Large Rifle
58	059100	*	AP Press
59	398346	1	10-24 x 1/2 SHCS
60	398293	1	V-Block #1
61	398297	1	V-Block #2
62	398294	1	V-Block #3
63	398292	1	V-Block #4
64	398295	1	V-Block #5
65	398296	1	V-Block #6
66	398324	1	Plastic Feed Tube Small Bushing
67	390651	2	3/16" Flat Washer SAE
68	390410	1	10-24 x 1/4 BHCS
69	398370	1	Case Feed Bowl Bushing
70	398388	4	1/4-20 x 1.50 SHCS
71	398416	1	O-Ring 7/8 OD, 11/16 ID
73	398361	1	Feed Tube Insert - Intermediate
74	398447	1	Case Feeder Stand 2-PC Upper
75	398449	1	1" Square Tube Connector
76	398448	1	Case Feeder Stand 2-PC Lower
77	399677	1	Case Feeder Tip Stop
78	399691	1	Cam Block Clamp
79	399730	1	¼-20 X 1.75 SHCS

* Optional Accessories: Sold Separately

LOCK-N-LOAD® AP™ CASE FEEDER

EXPLODED VIEW

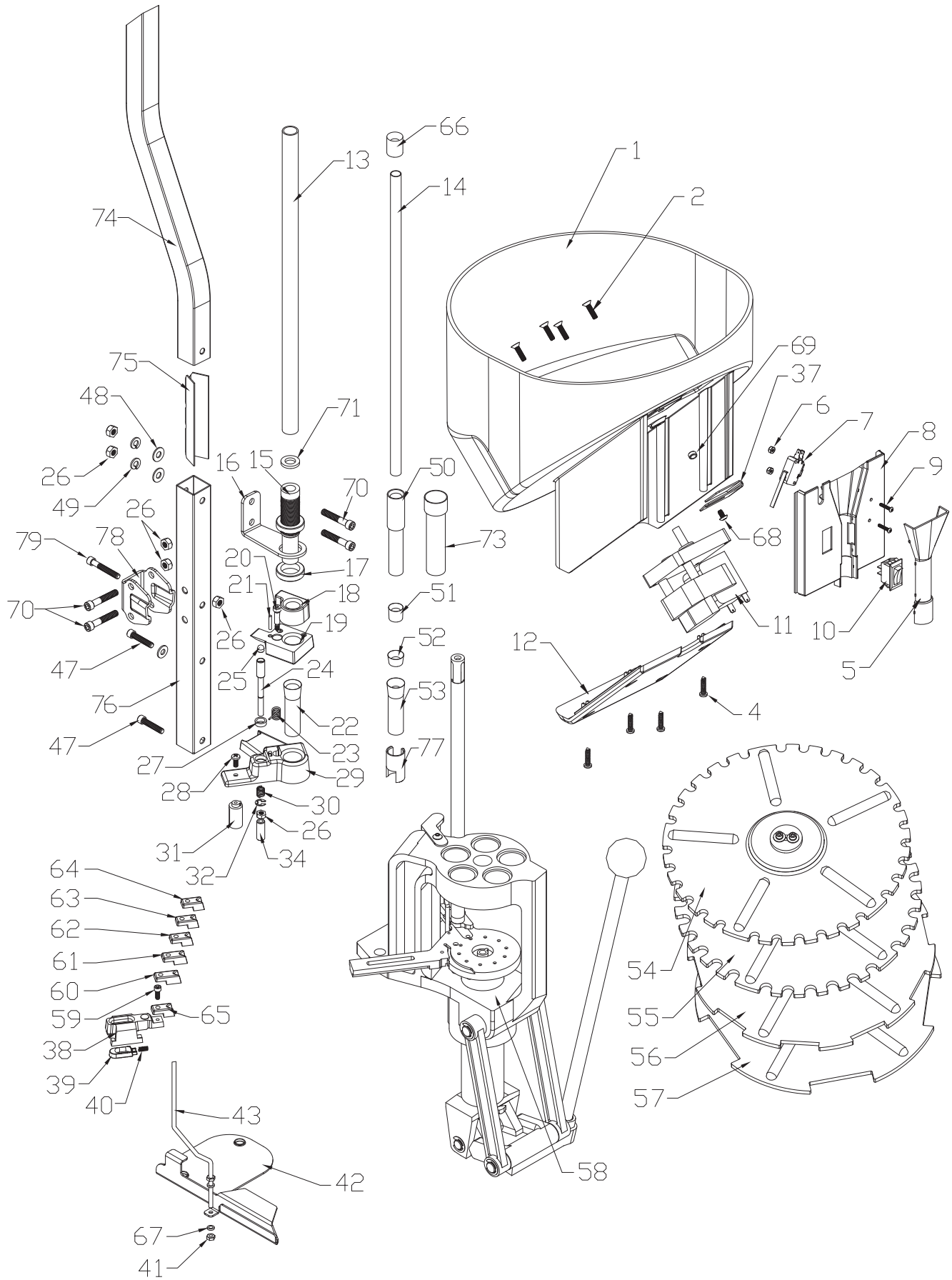

Attaching the Square Tubing to the frame of the AP™ Press.

- 3** Place the ¼" Flat Washers (48) on the ¼-20 x 1¼" Socket Head Cap Screw (SHCS) (47).
Place one SHCS through the Square Tubing (49) and thread into the Frame.
Repeat for the second Screw.
Tighten both screws down using a 3/16" Allen wrench.

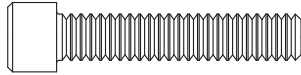

¼-20 x 1¼" Cap Screw (Full Size)

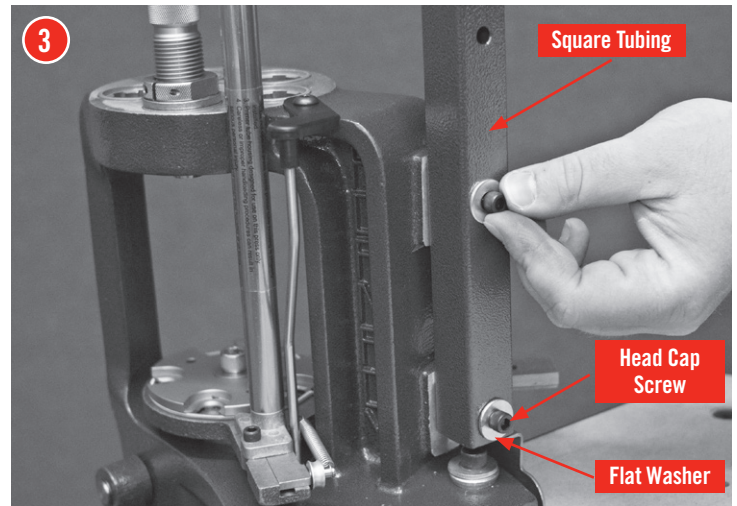

Adding the Case Slide on to the Sub-Plate

- 4** The Case Slide comes assembled with a piece of cardboard holding the spring and guide in place. DO NOT REMOVE this cardboard (fig. 1). Slide the assembly onto the sub plate and remove then the cardboard.

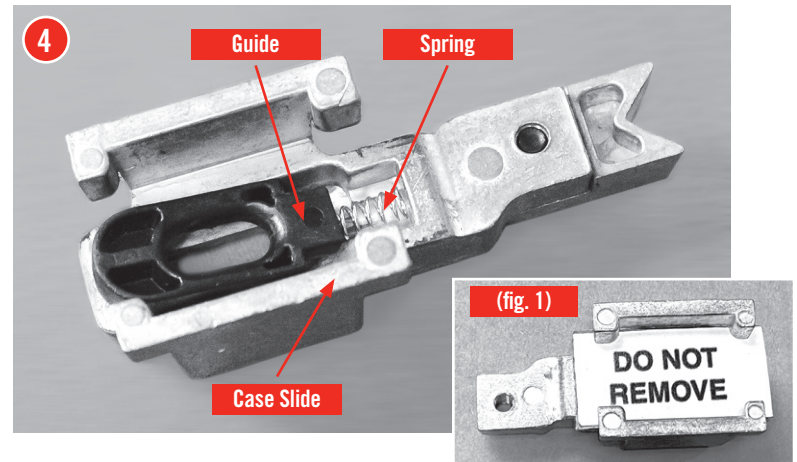

Inserting the Cam Wire into the Assembly.

- 5** Raise the Ram to the top of the stroke.
Screw one #10-32 Hex Nut (41) onto the Cam Wire (43) approximately 1" from the end.
Place one of the #10 Flat Washers (67) onto the Cam Wire.
From the bottom of the Sub-Plate, slide the non-threaded end of the Cam Wire through the slot of the Sub-Plate and through the Case Slide (38).
Place the threaded end of the Cam Wire through the hole of the tab on the Main Bracket.
Place the other Flat Washer and Hex Nut onto the bottom of the Cam Wire and tighten finger tight.
Lower the Ram.

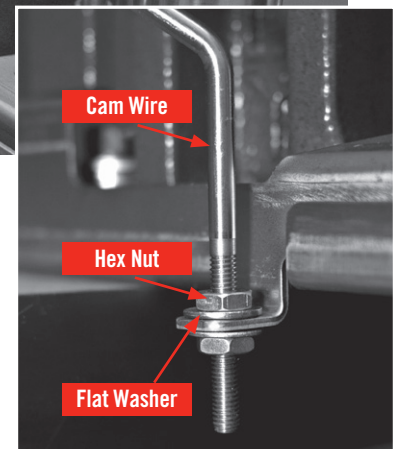
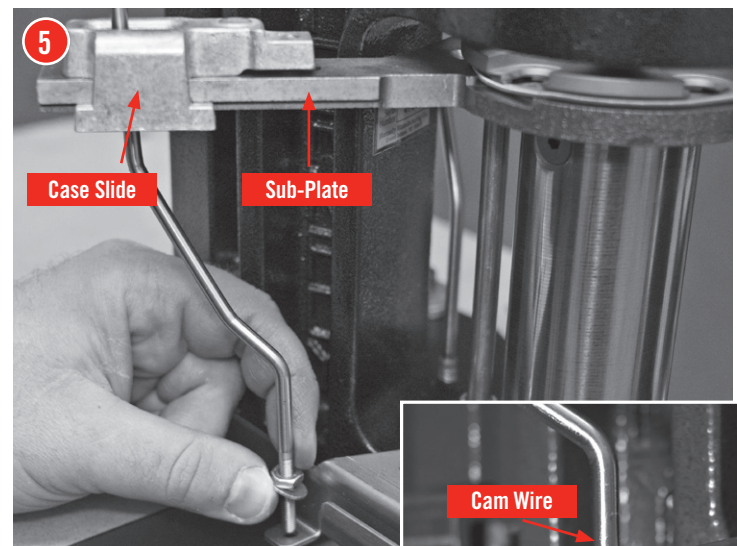

- 6** Place the ¼-20 X 1¼" Cap Screw (79) through the Cam Block Clamp

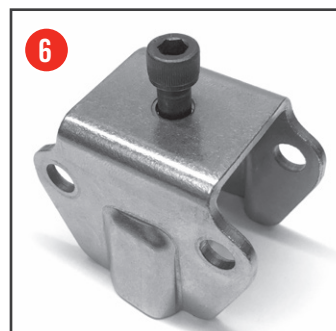

Case Escapement Bracket Assembly.

- 7 With the wide part of the grooves in the Cam Block Clamp down and the cap screw still through the Clamp, slide the Cap Screw through the Square Tubing and thread the Hex Nut the length of the nut.

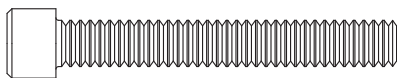

1/4-20 x 1 3/4" Cap Screw (79)
(Full Size)

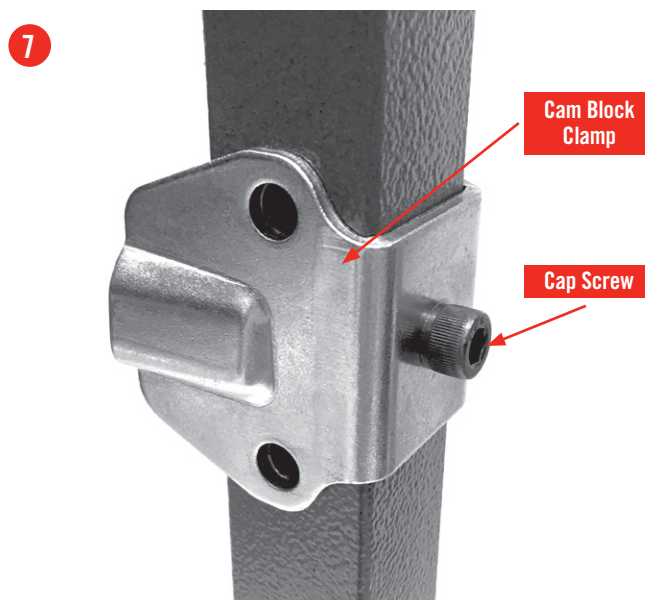

- 8 Rotate Pivot Block (29) so that the top face is parallel with the side of the Square Tubing. Slip Pivot Block over the Cap Screw so the Hex Nut is in the slot on the back of the Case Escapement Body. Rotate pivot block 90 degrees so it snaps into the Cam Block Clamp.

Slip Cam Wire (43) into the Cam Wire Support (31).

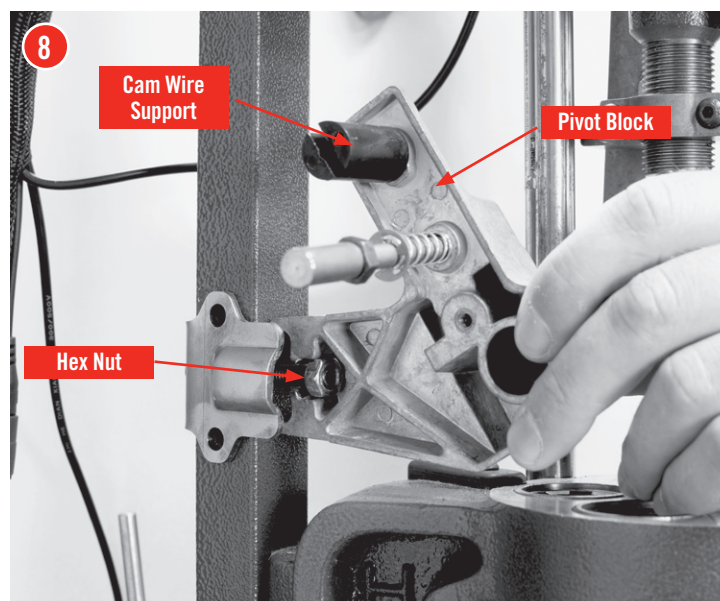

- 9 Tighten the Cap Screw while holding the Bracket level with the top of the frame.

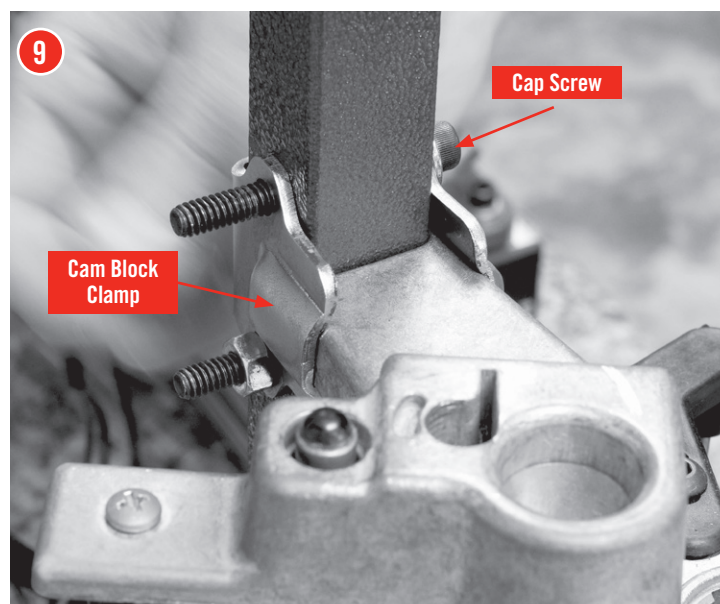

- 10** 7.5. Place a ¼-20 X 1½" Cap Screw (70) through the top hole on the Cam Block Clamp (78) and the Square Tubing. Place a Hex Nut on the other side of the Cap Screw and hand tighten.

Tighten both screws.

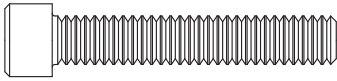

¼-20 x 1½" Cap Screw (70)
(Full Size)

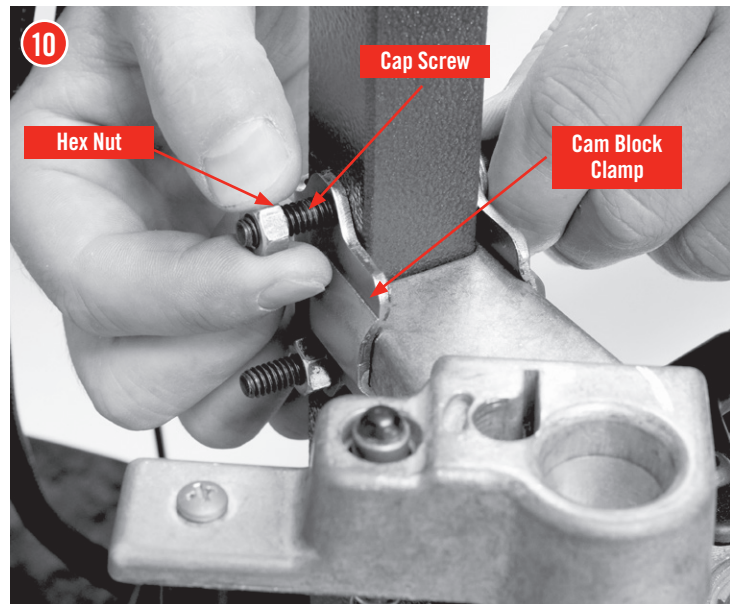

11 Feed Tube Mounting Bracket.

Slide the 1" Square Tube Connector (75) into the tubing (76) with the open end of the V forward until the bottom hole lines up with the uppermost hole in the tubing. Orient the Feed Tube Mounting Bracket (16) as shown in the exploded view. Place a ¼-20 x 1.50 SHCS (70) through the bottom hole, then through the square tubing. Place a ¼ Flat Washer (48) and ¼ Lock Washer (49) over the screw, and lightly thread on a ¼-20 Hex Head Nut (26).

Slide the Case Feeder Stand 2-PC Upper tube (74) over the Square Tube Connector (oriented as shown in the exploded view) until the two holes line up. Place a ¼-20 SHCS through the remaining hole in the Feed Tube Mounting Bracket and through the square tubing. Place a ¼ Flat Washer and ¼ Lock Washer over the screw, and thread on a ¼-20 Hex Head Nut. Tighten both Hex Head Nuts until snug.

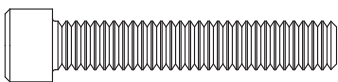

¼-20 x 1½" Cap Screw (Full Size)

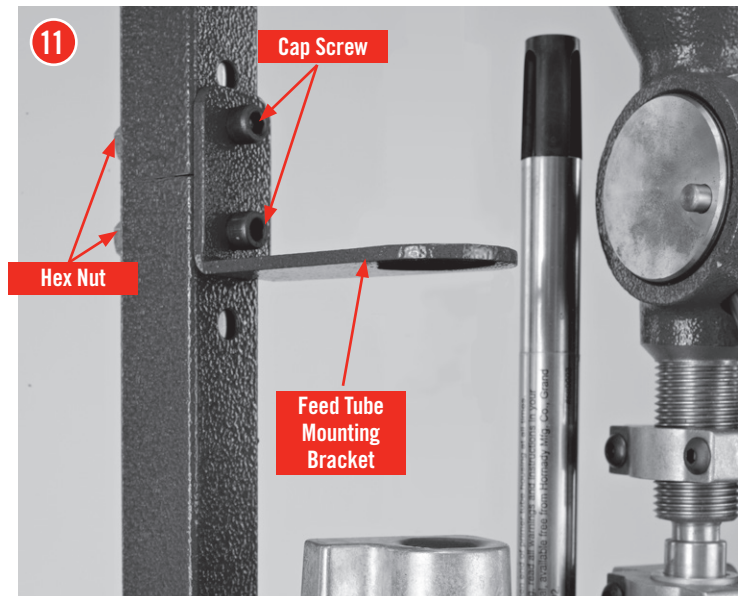

12 Installing the V-Block onto the case slide.

With the Ram at the bottom of the stroke (idle position), set the V-Block onto the Case Slide (38).

Refer to chart on page 12 for proper V-Block.

Place the #10-24 X 1/2 Cap Screw (59) through the hole of the V-Block and screw it into the Case Slide. Before you tighten the Cap Screw, push the V-Block back into the Case Slide and snug the Cap Screw with your fingers.

*The proper adjustments of the cam wire will be discussed later on **Change-Over: Case Feeder Page 13.***

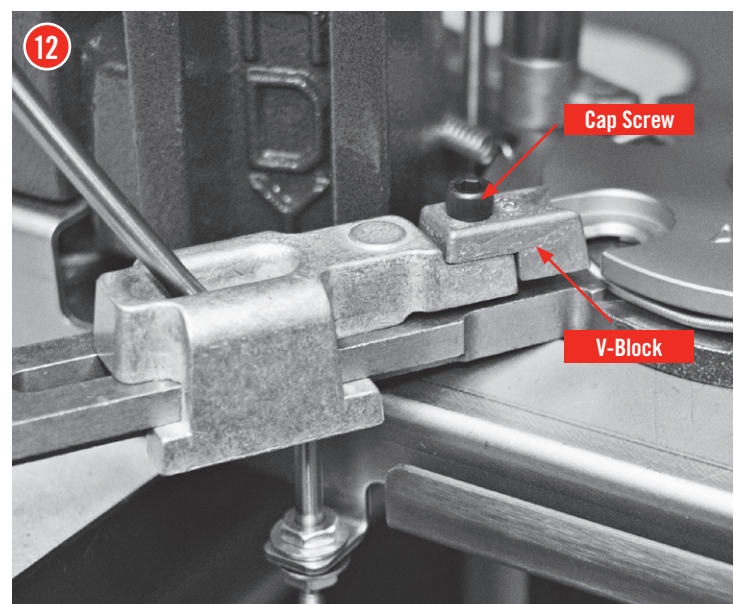

Assembling the Feed Tube End and Pivot.

13 If the maximum case diameter is larger than .43" you will need to use the large Drop Tube (22). If it is smaller, you will need the small Drop Tube (53). Place the correct one into the Pivot Block (29).

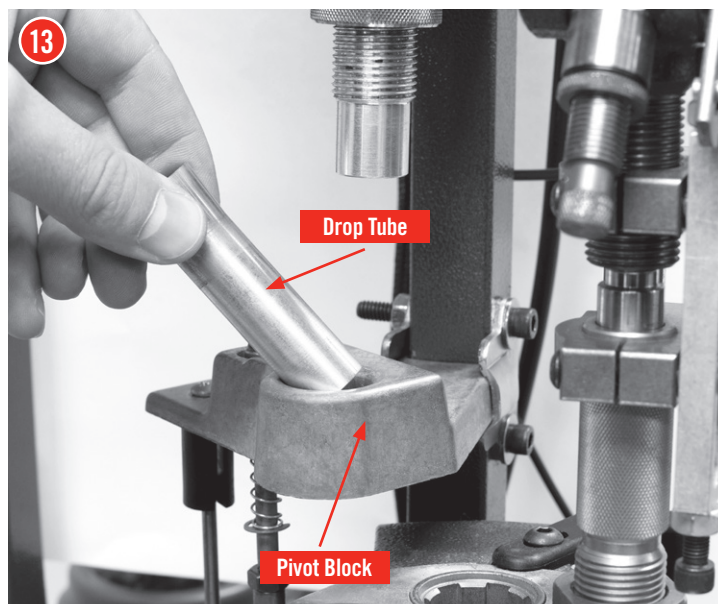

14 Place the Torsion Spring (23) into the slot in the Pivot Block (29), leaving the long leg on the top side. The Spring will only fit one way.

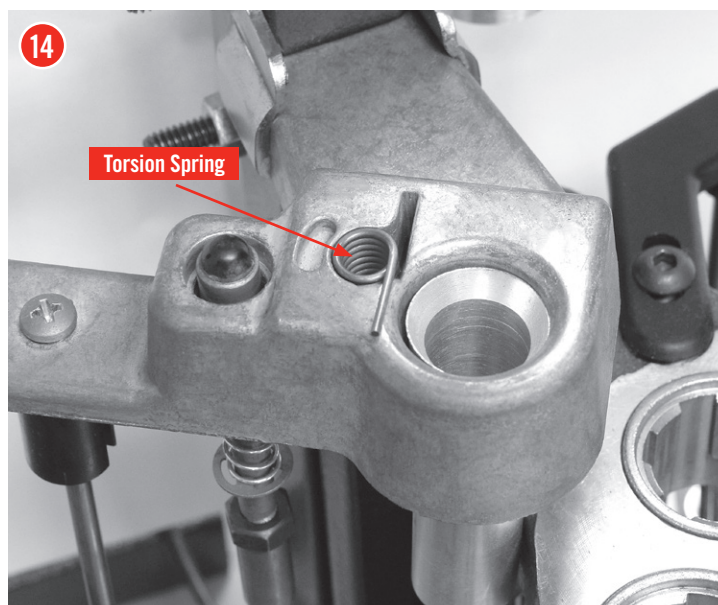

15 Set the Pivot (19) on top of the Pivot Block (29). Make sure you line up the under cut in the bottom of the pivot with the Torsion Spring (23). The leg of the Torsion Spring will fit into the slot on the Pivot.

When this fits together, the Pivot should fit on top of the Pivot Block. The Dowel Pin (21) in the Pivot will fit into the curved slot on the Pivot Block (29).

Then insert the Shoulder Bolt (20) into the pivot and into the pivot block and tighten with an Allen wrench.

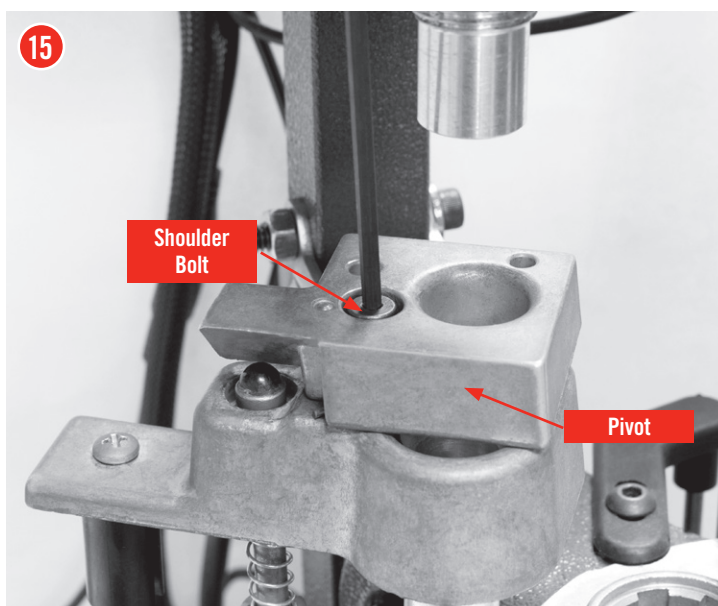

- 16** Actuate the Pivot by hand to make sure it will rotate smoothly and spring return back under the Feed Tube.

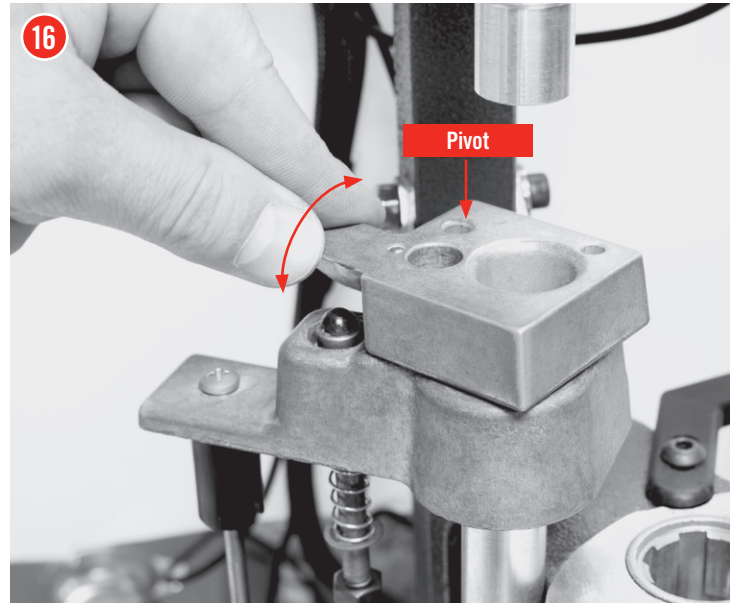

- 17** For small rifle cases, place the Pivot Adapter Bushing (51 or 52) into the hole of the Pivot Adapter.

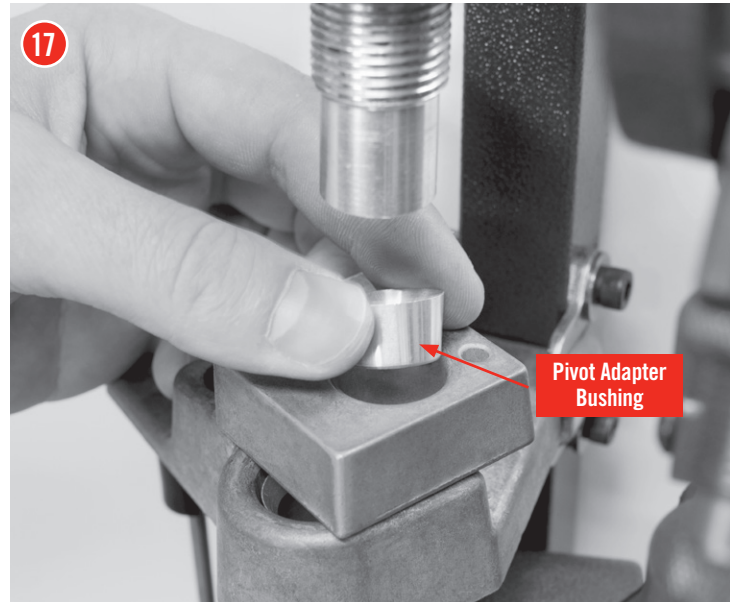

- 18** Place the Pivot Adapter (18) on top of the pivot for small rifle cases.
Refer to page 12 for proper Pivot Adapter Bushing (51 or 52).

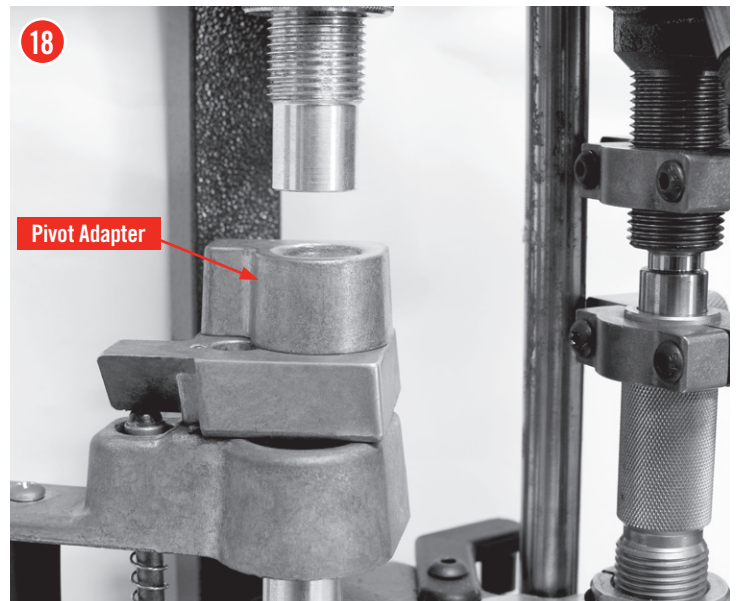

Placing the Feed Tube End on the Assembly.

- 19** Screw one Lock Ring (17) on the Feed Tube End Primary. Place it through the hole on the Feed Tube Mounting Bracket (16). Determine whether a Feed Tube Insert is necessary. (Refer to Page 12). If so, place the insert inside of the Feed Tube End Primary. Adjust the height of the Feed Tube End to have approximately 1/16" below the bottom of the tube to the case mouth. With some cases such as the 357 Mag, it may be necessary to adjust the Feed Tube End to where the case mouth sits up inside of the Feed Tube End. These are both starting points, and for your particular case, it may need to be adjusted a little differently. (*Long skinny cases, which are shorter than 1.50" long, will not work with the Pivot Adapter.*) They may need to be supported at the mouth of the case by the Feed Tube Ends. This will allow the case to feed down the Drop Tubes without falling over and causing double or triple feeds.

Screw on the other Lock Ring (17).

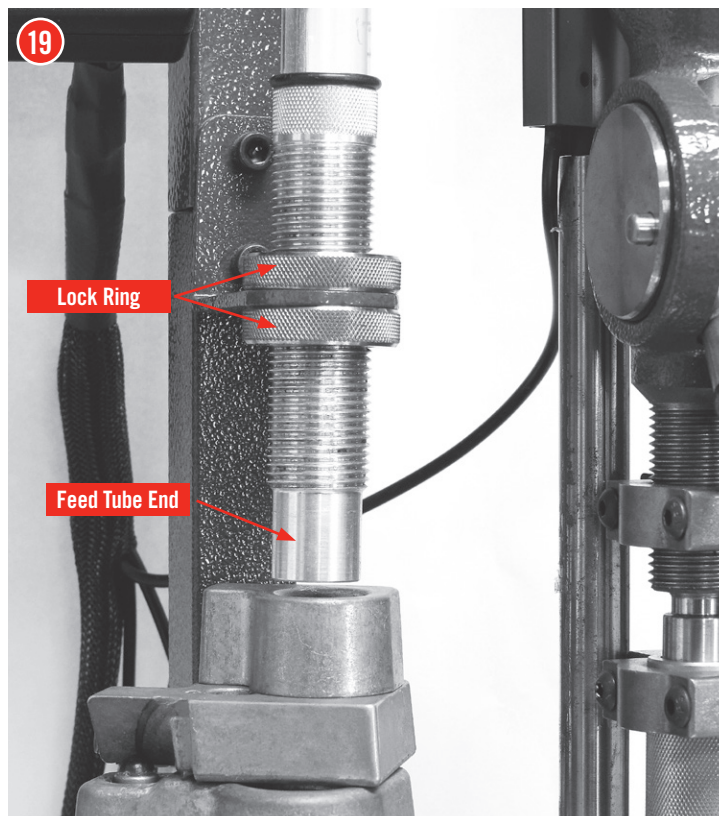

- 20** Select the proper Feed Tube and insert it in the top of the Feed Tube End. If you select the Small Feed Tube, you will have to use the Plastic Feed Tube Small Bushing (66). Refer to page 12.

(When feeding some cases, such as the 357 Mag, you may notice that the base of the case will not fall into the hole of the Pivot every time. The base will ride on the radius of the pivot hole. This is correct because when the Push Rod starts to rotate the Pivot, the case will fall into the hole.)

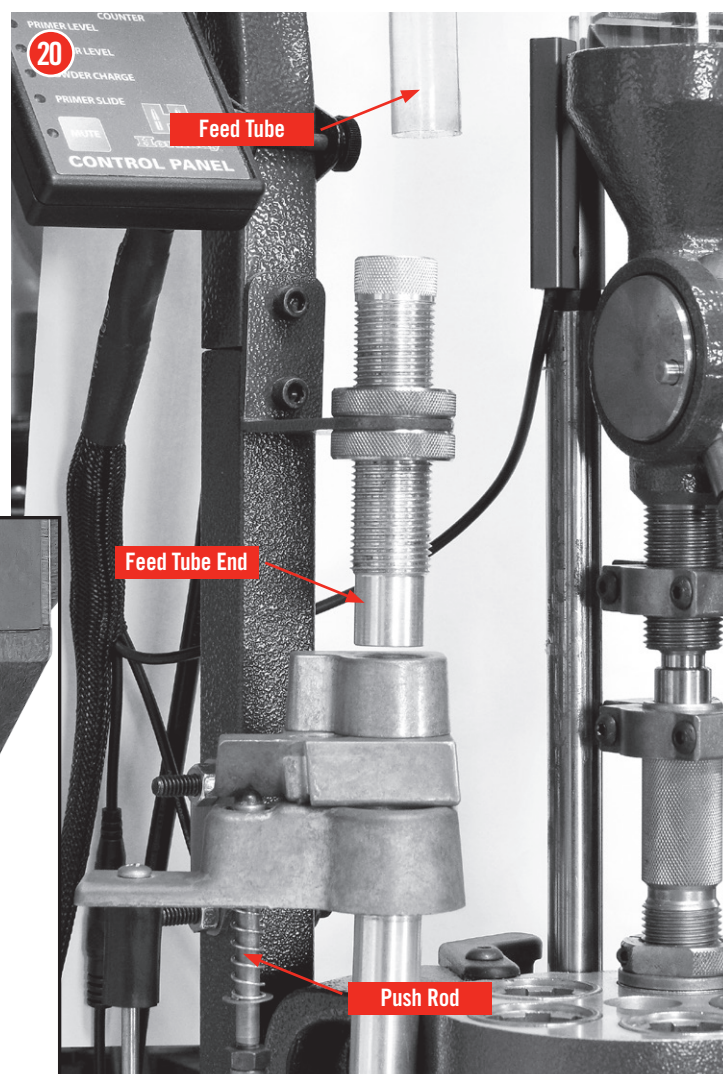
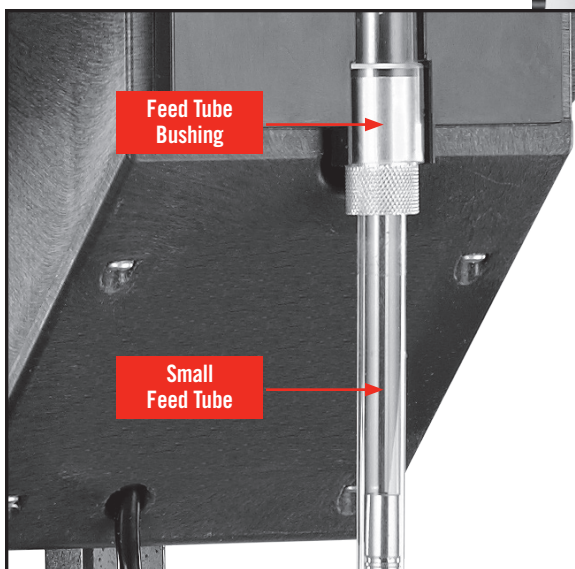

Placing the Feed Bowl Hopper on the Assembly

21 Select the Case Feed Plate for your application.
Refer to page 12.

To install the Case Feed Plate, place Feed Plate over the motor shaft and rotate until pawls on motor shaft engage the two slots on the bottom of the Feed Plate.

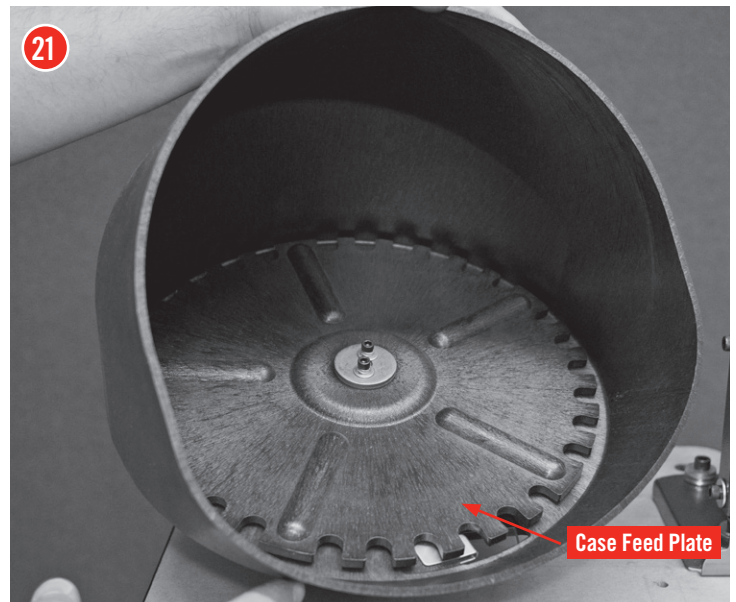

22 Slide Case Feed Hopper on to the Square Tubing and the Feed Tube.

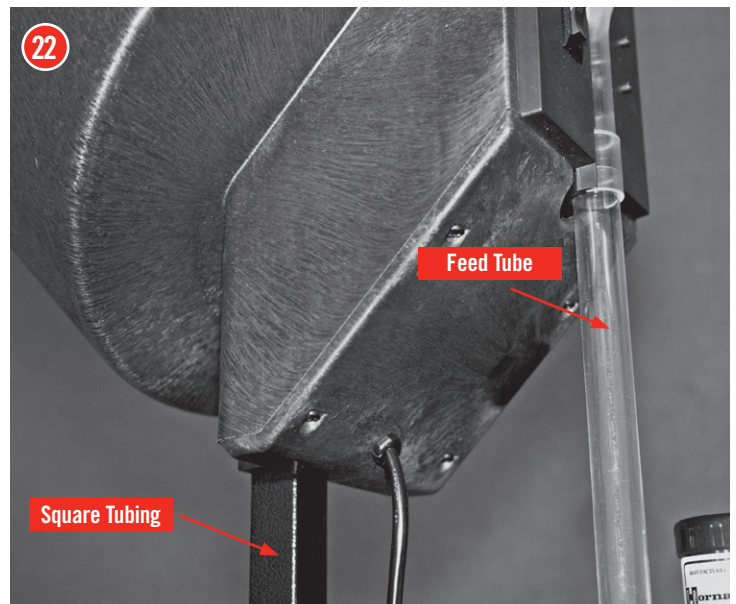

Maintenance of the Lock-N-Load® AP Case Feeder

As with all equipment, proper and routine maintenance will provide smooth operation and a longer life for your reloading press and Case Feeder. At the end of each reloading session, wipe off all spilled powder, any dirt, etc., from the press. Check all moving parts for dirt or spilled powder and remove with a clean rag.

SETUP / CHANGEOVER OF THE LOCK-N-LOAD® CASE FEEDER





The Hornady Lock-N-Load Case Feeder is capable of feeding both pistol and rifle cases. When changing cartridges, the following components on the Case Feeder may need to be changed or verified.

- Feed Plate
- Feed Tube
- Feed Tube End
- Pivot Adapter/Pivot Adapter Bushing
- Drop Tube
- V-Block
- Adjustment the Cam Wire
- Case Feed Door Adjustment

Refer to the chart below to determine the correct components needed to operate the Lock-N-Load® Case Feeder. Caliber specific sizing can be found on the charts on page 15-22.

Changing Feed Plate

Remove the existing Feed Plate by pulling straight up on the feed wheel to lift it off the motor drive shaft. To install the new plate, place Feed Plate over the motor shaft and rotate until pawls on motor shaft engage the two slots on the bottom of the Feed Plate.

	Base Diameter	Feed Tube	Feed Tube End Insert	Feed Plate	Pivot Adapter Bushing	Drop Tube
Small Pistol Plate 	<0.40"	SM - #14	Sm - #50	Sm Pistol #54 No. 095310	N/A	#53
	0.40" - .43"	LG - #13	Int - #73			
Large Pistol Plate 	>0.43"	LG - #13	-NONE- Feed Tube End Primary Only	Lg Pistol #55 No. 095312	N/A	#22
Small Rifle Plate 	<0.43"	SM - #14	Sm - #50	Sm Rifle #56 No. 095314	#18 & #51 or #52	#53
Large Rifle Plate 	>0.43"	LG - #13	-NONE- Feed Tube End Primary Only	Lg Rifle #57 No. 095316	N/A	#22

If the Feed Tube, Feed Tube End, Pivot Adapter, Pivot Adapter Bushing, or Drop Tube need to be changed; remove those items and refer to **Assembly: Case Feeder** starting on Page 2.

Determining the size of the Clear Feed Tube

The base or rim diameter of the cartridge case determines the size of the feed tube. In general, a case smaller than .43" in diameter will use the Small Tube and Small Tube Adapter. Cases larger than 0.43" will utilize the Large Feed Tube only.

Exception: 40 S&W and 10mm Auto will use the Intermediate Feed Tube Insert (73) with the Large Feed Tube (13).

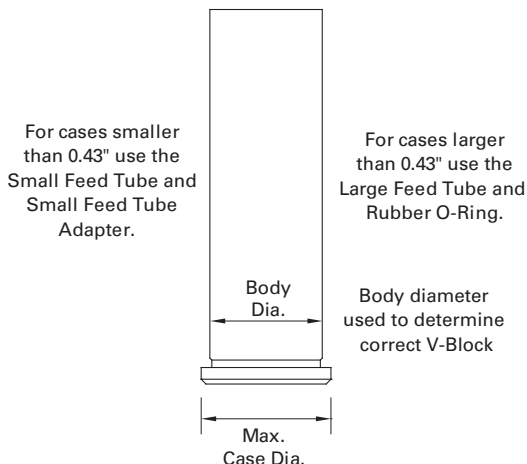

V-Block	Case Body Diameter
1	.27" - .30"
2	.37" - .39"
3	.35" - .38"
4	.42" - .47"
5	.46" - .58"
6	.41" - .44"

Determining the use of the Pivot Adapter and/or Pivot Adapter Bushing (Rifle Cases Only)

The Pivot Adapter is used with rifle cases to help guide the taller cases. You may also need to use the Pivot Adapter Bushing for rifle cases with a smaller base diameter (i.e. 223 Rem.).

Determining the correct Drop Tube

In general, the Drop Tube helps guide the case onto the press sub-plate. Again, a case smaller than .43" in diameter will use the Small Drop Tube, and cases larger than 0.43" will utilize the Large Drop Tube.

CHANGE-OVER

1 Replacing the V-Block

Refer to the chart and diagram on page 12 to determine the correct V-Block.

With the ram at the bottom of the stroke (idle position), set the V-Block onto the Case Slide.

Place the #10-24 X 1/2 Cap Screw through the hole of the V-Block and screw it into the Case Slide. Before you tighten the Cap Screw, push the V-Block back into the Case Slide and snug the Cap Screw with your fingers.

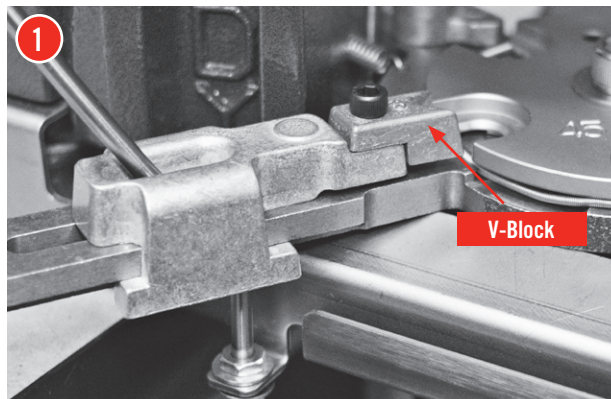

2 Place a case of the proper size into the shell plate and manually push the Case Slide and V-Block into the case.

Loosen the Cap Screw and continue to push the Case Slide into the case. Tighten the Cap Screw) with a 3/16" Allen wrench.

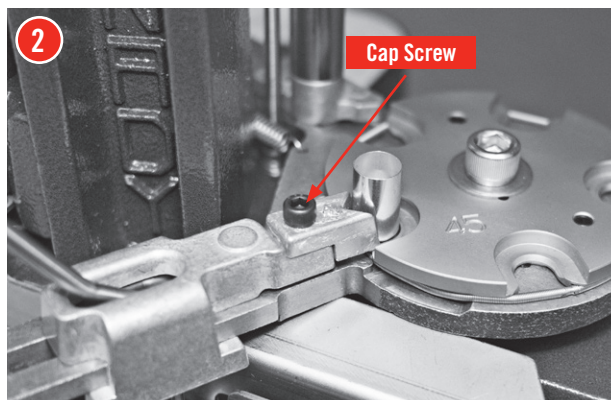

3 Raise the ram until the shell plate rotates and place a case (of the proper size) in front of the V-Block on the Sub-Plate. Lower the ram so the Case Slide will advance the case into the shell plate.

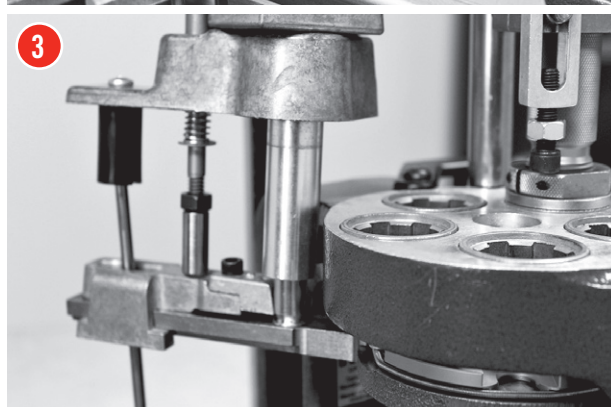

4 Adjusting the Cam Wire

The Cam Wire determines the timing of the Case Feed Slide and must be adjusted to allow the case to easily slide into the shell plate.

To adjust the Cam Wire, loosen both nuts so the wire can be moved either up or down.

If the cases are not fully seating into the shell plate, raise the Cam Wire.

If the cases are hitting the shell plate when feeding, or the shell plate cannot rotate, lower the Cam Wire.

Once the timing is correct, snug both nuts to the bracket and make sure the Cam Wire is centered in the Slide. This can be adjusted manually by rotating it a small amount around the threaded end. Tighten the nuts to complete the timing process. This timing setting is adequate for all cartridges and it should not be necessary to make future changes.

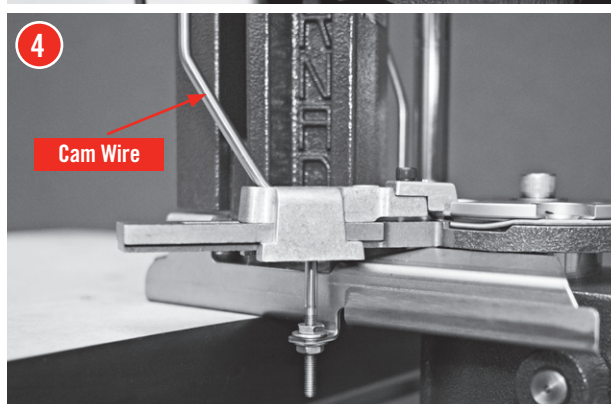

5 Case Feed Door Adjustments

The Case Feed Door is used to prevent cases from falling down the Drop Tube mouth first.

If loading pistol cases, the Case Feed Door should be opened completely by loosening the Button Head Screw with a 1/8" Hex Wrench. Re-tighten screw after completely opening the Case Feed Door.

If you are loading rifle cartridges, the length and weight of your cartridge will determine how far the door must be opened. This may take some trial and error.

Loosen the Button Head Cap Screw and slide the Case Feed Door Adjustment so the opening is approximately $\frac{3}{4}$ the length of the case. This is a preliminary setting. Place a hand-full of cases into the Case Feed Bowl, and turn on the Case Feeder

Observe to see if the cases will fall base first. If they do not, readjust the Case Feed Bowl Door Adjustment until they do without hanging up or getting caught. Re-tighten the Button Head Cap Screw.



TROUBLESHOOTING

Tips for Trouble-Free Operation of the Lock-N-Load® AP™ and Case Feeder

Problems	Solutions
Powder dropping around case	<ul style="list-style-type: none"> • Correct bushing in place? • Powder drop tube and measure adapter clean? • Bushing installed deep counter sink side up?
No primer in case	<ul style="list-style-type: none"> • Primer slide properly adjusted? • Correct primer punch installed? • Primer slide spring in place? • Correct primer slide installed? • Primer body rotated counterclockwise when installed? • Primer housing tube too tight?
Shell Plate will not advance or does not index on station	<ul style="list-style-type: none"> • Primer not fully seated? • Pawls correctly adjusted? • Make sure you have the latest shell plate version with the groove on the bottom side.
Cases do not feed into Dies	<ul style="list-style-type: none"> • Die mouths beveled? (If not, return to manufacturer for repair.) • Pawls timed correctly?
Gun powder is sticking in the powder measure, or inconsistent charge weights	<ul style="list-style-type: none"> • Is the inside surface dry and clean? • Try pouring a little powdered graphite through the powder measure for lubricant. Rub the outside of the powder hopper with a dryer sheet to eliminate static.
Case retainer spring won't fall off the shell plate or it is getting kinked	<ul style="list-style-type: none"> • Is there a burr on the shell plate where the spring groove and the case location meet? • Is there a burr on the sides of the slot on the sub-plate? (With a case feeder, when you are setting up the timing, do not run the case into the spring if the spring is up on the shell plate.)
Cases are hitting the back corner of the shell plate when feeding into the shell plate	Slow timing down or readjust V-Block location
Cases are not feeding into the shell plate far enough	Speed timing up or using the wrong V-Block
Cases are tipping when going into the shell plate	Readjust V-Block location
Cases are falling on top of the V-Block	Readjust the bracket, square tubing
Drop tube is tight against the AP™ frame; will not allow changing of tubes	Readjust the bracket, square tubing
Cases are falling mouth first out of the bowl	Close the door adjustment
Cases are getting caught in the open hole on the bowl	Open the door adjustment
The shell plate is hitting the V-Block when it's rotating	Lower the cam wire

Shell Plate Troubleshooting

Problems	Solutions
Timing is severely out of adjustment	The Index Pawls may have been damaged
The Shell Plate does not rotate freely after mounting	<ul style="list-style-type: none"> • You may be trying to use the wrong version of shell plate. Your shell plate must have a groove cut on the bottom side. • Dirt or debris between the shell plate and the drive hub • The Ball Detent bodies are not below flush on the underside of the Shell Plate. • The Shell Plate is warped or damaged

*If you reach a point where you cannot get the press to work, please call our technical service staff at 800-338-3220 or write us by visiting: Hornady.com/contact_us.

Dies & Reloading Essentials

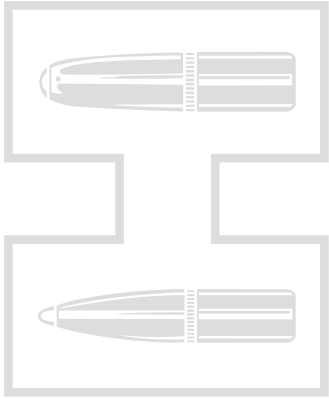

Series I: The most popular bottleneck rifle cartridges. Two die set: size die and bullet seater die.

Series II: The most popular handgun cartridges. Three die set: size die, expander die, seating die.

Series III: A second tier of bottleneck rifle cartridges. Two die set: size die and bullet seater die. For slightly less popular cartridges.

Series IV: Another tier of bottleneck rifle cartridges, obscure, almost semi-custom. Two die set: size die and seater die. Very low volume. Includes the Nitro Express cartridges.

Series V: The magnum handgun cartridges, and straight-wall rifle cartridges that require a special crimp (i.e. 450 Bushmaster is the only one). Four die set: size die, expander die, bullet seater die, and a special taper crimp die.

MATCH CARTRIDGE	Bullet Diameter (inches)	Die Set	Die Series	Full-Length Size Die	Seating Die	Expander Die	Taper Crimp Die Only	Neck Size Die	Shell Holder # / Item No.	Shell Plate # / Item No.	Case Feeder Plate Size / Item No.	Bullet Feeder Die	Trimmer Pilot # / Item No.	Primer Punch	Bullet Puller Collet # / Item No.	Modified Case
223 REM	0.224	544207	—	544229	044102	—	—	544227	#16 / 390556	#16 / 392616	Sm Rfl / 095314	095340	#1 / 390943	Small	#2 / 392155	A223
6MMx47 LAPUA	0.243	544610	—	046258	—	—	—	—	#1 / 390541	#1 / 392601	Sm Rfl / 095314	—	#3 / 390945	Small	#3 / 392156	—
6MM PPC	0.243	544241	—	544255	—	—	—	544253	#6 / 390546	#6 / 392606	Sm Rfl / 095314	—	#3 / 390945	Small	#3 / 392156	B6PPC
6MM BR REM	0.243	544249	—	544251	—	—	—	544259	#1 / 390541	#1 / 392601	Sm Rfl / 095314	—	#3 / 390945	Small	#3 / 392156	A6MMB
6MM ARC	0.243	544257	—	046264	—	—	—	—	#6 / 390546	#6 / 392606	Sm Rfl / 095314	—	#3 / 390945	Small	#3 / 392156	A6MMA
6MM CREEDMOOR	0.243	544247	—	046204	—	—	—	—	#1 / 390541	#1 / 392601	Lg Rfl / 095316	—	#3 / 390945	Large	#3 / 392156	A6MMC
6.5X47 LAPUA	0.264	544650	—	046260	—	—	—	—	#1 / 390541	#1 / 392601	— / —	—	#5 / 390947	Small	#4 / 392157	—
6.5X55	0.264	544281	—	046216	—	—	—	—	#19 / 390559	#19 / 392619	Lg Rfl / 095316	—	#5 / 390947	Large	#4 / 392157	B65X55
260 REM	0.264	544277	—	046214	—	—	—	—	#1 / 390541	#1 / 392601	Lg Rfl / 095316	—	#5 / 390947	Large	#4 / 392157	—
6.5 CREEDMOOR	0.264	544655	—	046282	—	—	—	—	#1 / 390541	#1 / 392601	Lg Rfl / 095316	—	#5 / 390947	Large	#4 / 392157	—
6.5-284 NORMA	0.264	544295	—	046218	—	—	—	—	#1 / 390541	#1 / 392601	Lg Rfl / 095316	—	#5 / 390947	Large	#4 / 392157	B65
6.5 PRC	0.264	544283	—	046288	—	—	—	—	#5 / 390545	#5 / 392605	Lg Rfl / 095316	—	#5 / 390947	Large	#4 / 392157	B65P
284 WIN	0.284	544303	—	046232	—	—	—	—	#1 / 390541	#1 / 392601	Lg Rfl / 095316	—	#7 / 390949	Large	#6 / 392159	—
280 ACKLEY IMP	0.284	544323	—	046228	—	—	—	—	#1 / 390541	#1 / 392601	Lg Rfl / 095316	—	#7 / 390949	Large	#6 / 392159	A280AI
7MM REM SA ULTRA MAG	0.284	544311	—	046224	—	—	—	—	#5 / 390545	#5 / 392605	Lg Rfl / 095316	—	#7 / 390949	Large	#6 / 392159	B7MMR
7MM REM MAG	0.284	544325	—	046234	—	—	—	—	#5 / 390545	#5 / 392605	Lg Rfl / 095316	—	#7 / 390949	Large	#6 / 392159	A7MMR
7MM WSM	0.284	544329	—	046226	—	—	—	—	#35 / 390575	#35 / 392635	Lg Rfl / 095316	—	#7 / 390949	Large	#6 / 392159	B7WS
308 WIN	0.308	544355	—	544359	—	—	—	544357	#1 / 390541	#1 / 392601	Lg Rfl / 095316	095345	#9 / 390951	Large	#7 / 392160	A308
30-06 SPRG	0.308	544339	—	046236	—	—	—	—	#1 / 390541	#1 / 392601	Lg Rfl / 095316	095345	#9 / 390951	Large	#7 / 392160	A3006
300 WSM	0.308	544353	—	046242	—	—	—	046057	#35 / 390575	#35 / 392635	Lg Rfl / 095316	095345	#9 / 390951	Large	#7 / 392160	B300W
300 WIN MAG	0.308	544351	—	046240	—	—	—	—	#5 / 390545	#5 / 392605	Lg Rfl / 095316	095345	#9 / 390951	Large	#7 / 392160	A300M
300 PRC	0.308	544349	—	046338	—	—	—	—	#5 / 390545	#5 / 392605	Lg Rfl / 095316	095345	#9 / 390951	Large	#7 / 392160	B300P
300 NORMA MAG	0.308	544371	—	046248	—	—	—	—	#43 / 390583	— / —	Lg Rfl / 095316	095345	#9 / 390951	Large	#7 / 392160	—
300 REM ULTRA MAG	0.308	544367	—	046246	—	—	—	—	#5 / 390545	#5 / 392605	Lg Rfl / 095316	095345	#9 / 390951	Large	#7 / 392160	B300
338 NORMA MAG	0.338	544397	—	046250	—	—	—	046058	#43 / 390583	— / —	Lg Rfl / 095316	—	#13 / 390955	Large	#9 / 392162	—
338 LAPUA MAG	0.338	544399	—	046252	—	—	—	—	#43 / 390583	— / —	Lg Rfl / 095316	—	#13 / 390955	Large	#9 / 392162	C388L

APPENDIX A

RIFLE CARTRIDGE	Bullet Diameter (inches)	Die Set	Die Series	Full-Length Size Die	Seating Die	Expander Die	Taper Crimp Die Only	Neck Size Die	Shell Holder # / Item No.	Shell Plate # / Item No.	Case Feeder Plate Size / Item No.	Bullet Feeder Die	Trimmer Pilot # / Item No.	Primer Punch	Bullet Puller Collet # / Item No.	Modified Case
BLANK CART 22-45 CAL	—	544591	IV	—	—	—	—	—	— / —	— / —	— / —	—	— / —	—	— / —	—
17 HORNET	0.172	546118	I	046202	044101	—	—	—	#3 / 390543	#3 / 392603	Sm Rfl / 095314	—	^ / 390942	Small	#1 / 392154	A17H
17 REM FIREBALL	0.172	546117	III	046200	044101	—	—	—	#16 / 390556	#16 / 392616	Sm Rfl / 095314	—	^ / 390942	Small	#1 / 392154	—
17 REM	0.172	546200	III	046201	044101	—	—	—	#16 / 390556	#16 / 392616	Sm Rfl / 095314	—	^ / 390942	Small	#1 / 392154	A17
17-222	0.172	546202	IV	—	—	—	—	—	#16 / 390556	#16 / 392616	Sm Rfl / 095314	—	^ / 390942	Small	#1 / 392154	—
17-223	0.172	546204	IV	—	—	—	—	—	#16 / 390556	#16 / 392616	Sm Rfl / 095314	—	^ / 390942	Small	#1 / 392154	—
20 VT	0.204	546205	III	046206	044139	—	—	046038	#16 / 390556	#16 / 392616	Sm Rfl / 095314	—	#22 / 390940	Small	#14 / 392167	—
20 TACTICAL	0.204	546209	III	046208	044139	—	—	046038	#16 / 390556	#16 / 392616	Sm Rfl / 095314	—	#22 / 390940	Small	#14 / 392167	—
204 RUGER	0.204	546201	I	046590	044139	—	—	046038	#16 / 390556	#16 / 392616	Sm Rfl / 095314	—	#22 / 390940	Small	#14 / 392167	B204
5.45X39	0.221	546199	III	046561	044220	—	—	—	#56 / 390611	#56 / 392656	Sm Rfl / 095314	—	#1 / 390943	Small	#2 / 392155	—
22 HORNET	0.224	546212	I	046213	044206	—	—	046066	#3 / 390543	#3 / 392603	Sm Rfl / 095314	—	#1 / 390943	Small	#2 / 392155	—
22 K-HORNET	0.224	546214	IV	—	—	—	—	046066	#3 / 390543	#3 / 392603	Sm Rfl / 095314	—	#1 / 390943	Small	#2 / 392155	—
5.7X28MM	0.224	546203	III	046212	044136	—	—	—	#37 / 390577	— / —	Sm Rfl / 095314	—	#1 / 390943	Small	#2 / 392155	—
218 BEE	0.224	546206	IV	—	—	—	—	046066	#7 / 390547	#7 / 392607	Sm Rfl / 095314	—	#1 / 390943	Small	#2 / 392155	A218
221 REM FIREBALL	0.224	546210	III	046211	044102	—	—	046040	#16 / 390556	#16 / 392616	Sm Rfl / 095314	095340	#1 / 390943	Small	#2 / 392155	A221
222 REM	0.224	546224	I	046225	044102	—	—	046040	#16 / 390556	#16 / 392616	Sm Rfl / 095314	095340	#1 / 390943	Small	#2 / 392155	A222
223 REM	0.224	546228	I	046229	044102	—	—	046040	#16 / 390556	#16 / 392616	Sm Rfl / 095314	095340	#1 / 390943	Small	#2 / 392155	A223
22 PPC	0.224	546216	IV	—	—	—	—	046053	#6 / 390546	#6 / 392606	Sm Rfl / 095314	095340	#1 / 390943	Small	#2 / 392155	—
5.6X50 MAG	0.224	546234	IV	—	—	—	—	046040	#16 / 390556	#16 / 392616	Sm Rfl / 095314	095340	#1 / 390943	Small	#2 / 392155	—
219 ZIPPER	0.224	546208	IV	—	—	—	—	046040	#2 / 390542	#2 / 392602	Lg Rfl / 095316	095340	#1 / 390943	Large	#2 / 392155	—
225 WIN	0.224	546232	III	046233	044127	—	—	046040	#4 / 390544	#4 / 392604	Lg Rfl / 095316	095340	#1 / 390943	Large	#2 / 392155	—
22 NOSLER	0.224	546207	III	046286	044127	—	—	046040	#16 / 390556	#16 / 392616	Sm Rfl / 095314	095340	#1 / 390943	Small	#2 / 392155	—
224 VALKYRIE	0.224	546211	I	046559	044102	—	—	046040	#12 / 390552	#12 / 392612	Lg Rfl / 095316	095340	#1 / 390943	Small	#2 / 392155	A224
224 WBY MAG	0.224	546230	IV	—	—	—	—	046040	#17 / 390557	— / —	Lg Rfl / 095316	095340	#1 / 390943	Large	#2 / 392155	—
22-250 REM	0.224	546220	I	046221	044102	—	—	046040	#1 / 390541	#1 / 392601	Lg Rfl / 095316	095340	#1 / 390943	Large	#2 / 392155	A22250
22-250 ACKLEY IMP	0.224	546219	IV	—	—	—	—	046040	#1 / 390541	#1 / 392601	Lg Rfl / 095316	095340	#1 / 390943	Large	#2 / 392155	—
22 CREEDMOOR	0.224	546217	III	046560	044127	—	—	046040	#1 / 390541	#1 / 392601	Lg Rfl / 095316	095340	#1 / 390943	Large	#2 / 392155	B22C
220 SWIFT	0.224	546222	I	046223	044127	—	—	046054	#4 / 390544	#4 / 392604	Lg Rfl / 095316	095340	#1 / 390943	Large	#2 / 392155	A220
5.6X57	0.224	546236	IV	—	—	—	—	—	#1 / 390541	#1 / 392601	Lg Rfl / 095316	—	#1 / 390943	Large	#2 / 392155	—
223 WSSM	0.224	546223	III	046558	044707	—	—	—	#35 / 390575	#35 / 392635	Lg Rfl / 095316	—	#1 / 390943	Large	#2 / 392155	B223
22-6MM	0.224	546249	III	046238	044127	—	—	046054	#1 / 390541	#1 / 392601	Lg Rfl / 095316	095340	#1 / 390943	Large	#2 / 392155	—
22 SAVAGE HP	0.227	546240	IV	—	—	—	—	—	#2 / 390542	#2 / 392602	Lg Rfl / 095316	—	#2 / 390944	Large	#2 / 392155	—
5.6X52R	0.227	546238	IV	—	—	—	—	—	#2 / 390542	#2 / 392602	Lg Rfl / 095316	—	#2 / 390944	Large	#2 / 392155	—
6MM-223	0.243	546248	IV	—	—	—	—	046047	#16 / 390556	#16 / 392616	Sm Rfl / 095314	—	#3 / 390945	Small	#3 / 392156	—
6MM TCU	0.243	546256	IV	—	—	—	—	046047	#16 / 390556	#16 / 392616	Sm Rfl / 095314	—	#3 / 390945	Small	#3 / 392156	—
6MMX47 REM	0.243	546258	IV	—	—	—	—	046047	#16 / 390556	#16 / 392616	Sm Rfl / 095314	—	#3 / 390945	Small	#3 / 392156	—
6MM PPC	0.243	546254	IV	—	—	—	—	046052	#6 / 390546	#6 / 392606	Sm Rfl / 095314	—	#3 / 390945	Small	#3 / 392156	B6PPC

*Discontinued SKUs with limited inventory.

APPENDIX A

APPENDIX A

RIFLE CARTRIDGE	Bullet Diameter (inches)	Die Set	Die Series	Full-Length Size Die	Seating Die	Expander Die	Taper Crimp Die Only	Neck Size Die	Shell Holder # / Item No.	Shell Plate # / Item No.	Case Feeder Plate Size / Item No.	Bullet Feeder Die	Trimmer Pilot # / Item No.	Primer Punch	Bullet Puller Collet # / Item No.	Modified Case
6MM BR REM	0.243	546432	IV	—	—	—	—	046047	#1 / 390541	#1 / 392601	Sm Rfl / 095314	—	#3 / 390945	Small	#3 / 392156	A6MMB
6MM ARC	0.243	546251	III	046262	044244	—	—	046047	#6 / 390546	#6 / 392606	Sm Rfl / 095314	—	#3 / 390945	Small	#3 / 392156	A6MMA
6MM HAGAR	0.243	546303	IV	—	—	—	—	—	#12 / 390552	#12 / 392612	Sm Rfl / 095314	—	#3 / 390945	Large	#3 / 392156	—
243 WIN	0.243	546244	I	046245	044103	—	—	046041	#1 / 390541	#1 / 392601	Lg Rfl / 095316	—	#3 / 390945	Large	#3 / 392156	A243
6MM REM	0.243	546246	III	046247	044103	—	—	046041	#1 / 390541	#1 / 392601	Lg Rfl / 095316	—	#3 / 390945	Large	#3 / 392156	A6MM
6MM CREEDMOOR	0.243	546295	I	046254	044183	—	—	046041	#1 / 390541	#1 / 392601	Lg Rfl / 095316	—	#3 / 390945	Large	#3 / 392156	A6MMC
6MM-284	0.243	546250	IV	—	—	—	—	046041	#1 / 390541	#1 / 392601	Lg Rfl / 095316	—	#3 / 390945	Large	#3 / 392156	—
240 WBY MAG	0.243	546242	IV	—	—	—	—	046041	#1 / 390541	#1 / 392601	Lg Rfl / 095316	—	#3 / 390945	Large	#3 / 392156	B240
243 WSSM	0.243	546225	III	046557	044708	—	—	—	#35 / 390575	#35 / 392635	Lg Rfl / 095316	—	#3 / 390945	Large	#3 / 392156	B243
25-20 WIN	0.257	546264	IV	—	—	—	—	—	#7 / 390547	#7 / 392607	Sm Rfl / 095314	—	#4 / 390946	Small	#4 / 392157	—
256 WIN	0.257	546272	IV	—	—	—	—	—	#6 / 390546	#6 / 392606	Sm Rfl / 095314	—	#4 / 390946	Large	#4 / 392157	—
25-35 WIN	0.257	546266	IV	—	—	—	—	—	#2 / 390542	#2 / 392602	Lg Rfl / 095316	—	#4 / 390946	Large	#4 / 392157	—
25 REM	0.257	546260	III	046276	044104	—	—	—	#12 / 390552	#12 / 392612	Lg Rfl / 095316	—	#4 / 390946	Large	#4 / 392157	—
250 SAVAGE	0.257	546270	IV	—	—	—	—	046042	#1 / 390541	#1 / 392601	Lg Rfl / 095316	—	#4 / 390946	Large	#4 / 392157	A250
257 ROBERTS	0.257	546274	III	046275	044104	—	—	046042	#1 / 390541	#1 / 392601	Lg Rfl / 095316	—	#4 / 390946	Large	#4 / 392157	A257
25 WSSM	0.257	546263	IV	—	—	—	—	—	#35 / 390575	#35 / 392635	Lg Rfl / 095316	—	#4 / 390946	Large	#4 / 392157	B25
25-06 REM	0.257	546262	I	046263	044104	—	—	046042	#1 / 390541	#1 / 392601	Lg Rfl / 095316	—	#4 / 390946	Large	#4 / 392157	A2506
257 WBY MAG	0.257	546276	III	046277	044104	—	—	046042	#5 / 390545	#5 / 392605	Lg Rfl / 095316	—	#4 / 390946	Large	#4 / 392157	B257
6.5 TCU	0.264	546296	IV	—	—	—	—	046048	#16 / 390556	#16 / 392616	Sm Rfl / 095314	—	#5 / 390947	Small	#4 / 392157	—
6.5 JAP	0.264	546290	III	046291	044106	—	—	046043	#34 / 390574	— / —	Lg Rfl / 095316	—	#5 / 390947	Large	#4 / 392157	—
6.5 GRENDDEL	0.264	546291	I	046598	044164	—	—	—	#6 / 390546	#6 / 392606	Sm Rfl / 095314	—	#5 / 390947	Small	#4 / 392157	A65G
6.5X54 M-SCH	0.264	546292	IV	—	—	—	—	046043	#20 / 390560	— / —	Lg Rfl / 095316	—	#5 / 390947	Large	#4 / 392157	—
6.5X55	0.264	546282	I	046283	044106	—	—	046043	#19 / 390559	#19 / 392619	Lg Rfl / 095316	—	#5 / 390947	Large	#4 / 392157	B65X55
260 REM	0.264	546269	III	046441	044106	—	—	046043	#1 / 390541	#1 / 392601	Lg Rfl / 095316	—	#5 / 390947	Large	#4 / 392157	A260
6.5 CREEDMOOR	0.264	546289	I	046596	044135	—	—	046043	#1 / 390541	#1 / 392601	Lg Rfl / 095316	—	#5 / 390947	Large	#4 / 392157	A65C
6.5X57	0.264	546284	III	046285	044106	—	—	046043	#1 / 390541	#1 / 392601	Lg Rfl / 095316	—	#5 / 390947	Large	#4 / 392157	—
6.5-284	0.264	546301	III	046443	044106	—	—	046043	#1 / 390541	#1 / 392601	Lg Rfl / 095316	—	#5 / 390947	Large	#4 / 392157	B65
6.5-06	0.264	546280	III	046281	044123	—	—	046043	#1 / 390541	#1 / 392601	Lg Rfl / 095316	—	#5 / 390947	Large	#4 / 392157	—
6.5 REM MAG	0.264	546294	IV	—	—	—	—	046043	#5 / 390545	#5 / 392605	Lg Rfl / 095316	—	#5 / 390947	Large	#4 / 392157	—
264 WIN MAG	0.264	546278	III	046279	044123	—	—	046043	#5 / 390545	#5 / 392605	Lg Rfl / 095316	—	#5 / 390947	Large	#4 / 392157	A264
6.5 PRC	0.264	546281	I	046284	044123	—	—	—	#5 / 390545	#5 / 392605	Lg Rfl / 095316	—	#5 / 390947	Large	#4 / 392157	B65P
6.5 WBY RPM	0.264	546287	IV	—	—	—	—	—	#1 / 390541	#1 / 392601	Lg Rfl / 095316	—	#5 / 390947	Large	#4 / 392157	—
6.5X68	0.264	546286	III	046287	044123	—	—	046043	#30 / 390570	#30 / 392630	Lg Rfl / 095316	—	#5 / 390947	Large	#4 / 392157	—
26 NOSLER	0.264	546279	III	046280	044191	—	—	—	#5 / 390545	#5 / 392605	Lg Rfl / 095316	—	#5 / 390947	Large	#4 / 392157	B26N
6.5-300 WBY MAG	0.264	546283	IV	—	—	—	—	046043	#5 / 390545	#5 / 392605	Lg Rfl / 095316	—	#5 / 390947	Large	#4 / 392157	—
6.5X52 CARCANO	0.267	546288	III	046289	044134	—	—	046043	#21 / 390561	— / —	Lg Rfl / 095316	—	#5 / 390947	Large	#4 / 392157	—

APPENDIX A

RIFLE CARTRIDGE	Bullet Diameter (inches)	Die Set	Die Series	Full- Length Size Die	Seating Die	Expander Die	Taper Crimp Die Only	Neck Size Die	Shell Holder # / Item No.	Shell Plate # / Item No.	Case Feeder Plate Size / Item No.	Bullet Feeder Die	Trimmer Pilot # / Item No.	Primer Punch	Bullet Puller Collet # / Item No.	Modified Case
270 REN	0.277	—	—	—	—	—	—	—	#3 / 390543	#3 / 392603	Sm Rfl / 095314	—	#6 / 390948	Small	#5 / 392158	—
6.8MM REM SPC	0.277	546299	III	046711	044713	—	—	—	#12 / 390552	#12 / 392612	Lg Rfl / 095316	—	#6 / 390948	Small	#5 / 392158	A68SPC
270 WIN	0.277	546300	I	046301	044107	—	—	046051	#1 / 390541	#1 / 392601	Lg Rfl / 095316	—	#6 / 390948	Large	#5 / 392158	A270
270 WSM	0.277	546297	I	046450	044161	—	—	046055	#35 / 390575	#35 / 392635	Lg Rfl / 095316	—	#6 / 390948	Large	#5 / 392158	B270W*
270 WBV MAG	0.277	546298	III	046299	044107	—	—	046051	#5 / 390545	#5 / 392605	Lg Rfl / 095316	—	#6 / 390948	Large	#5 / 392158	B270*
7MM-223 INGRAM	0.284	546318	IV	—	—	—	—	046049	#16 / 390556	#16 / 392616	Sm Rfl / 095314	—	#7 / 390949	Small	#6 / 392159	—
7MM TCU	0.284	546328	IV	—	—	—	—	046049	#16 / 390556	#16 / 392616	Sm Rfl / 095314	—	#7 / 390949	Small	#6 / 392159	—
7MM BR REM	0.284	546324	IV	—	—	—	—	046049	#1 / 390541	#1 / 392601	Sm Rfl / 095314	—	#7 / 390949	Large	#6 / 392159	A7MM*
7-30 WATERS	0.284	546304	IV	—	—	—	—	046049	#2 / 390542	#2 / 392602	Lg Rfl / 095316	—	#7 / 390949	Large	#6 / 392159	—
7X57	0.284	546308	III	046309	044133	—	—	046044	#1 / 390541	#1 / 392601	Lg Rfl / 095316	—	#7 / 390949	Large	#6 / 392159	A7X57
7X57R	0.284	546311	III	046310	044133	—	—	046044	#13 / 390553	#13 / 392613*	Lg Rfl / 095316	—	#7 / 390949	Large	#6 / 392159	—
7MM-08 REM	0.284	546316	I	046317	044108	—	—	046044	#1 / 390541	#1 / 392601	Lg Rfl / 095316	—	#7 / 390949	Large	#6 / 392159	A7MM08
284 WIN	0.284	546302	III	046303	044108	—	—	046044	#1 / 390541	#1 / 392601	Lg Rfl / 095316	—	#7 / 390949	Large	#6 / 392159	—
280 REM	0.284	546320	I	046321	044133	—	—	046044	#1 / 390541	#1 / 392601	Lg Rfl / 095316	—	#7 / 390949	Large	#6 / 392159	A280
280 ACKLEY IMP	0.284	546321	III	046304	044133	—	—	046044	#1 / 390541	#1 / 392601	Lg Rfl / 095316	—	#7 / 390949	Large	#6 / 392159	A280AI
7X65R	0.284	546314	IV	—	—	—	—	046044	#13 / 390553	#13 / 392613*	Lg Rfl / 095316	—	#7 / 390949	Large	#6 / 392159	—
7X61 S&H	0.284	546310	IV	—	—	—	—	046044	#35 / 390575	#35 / 392635	Lg Rfl / 095316	—	#7 / 390949	Large	#6 / 392159	—
7X64	0.284	546312	IV	—	—	—	—	046044	#1 / 390541	#1 / 392601	Lg Rfl / 095316	—	#7 / 390949	Large	#6 / 392159	B764
7MM REM SA ULTRA MAG	0.284	546309	III	046452	044108	—	—	046056	#5 / 390545	#5 / 392605	Lg Rfl / 095316	—	#7 / 390949	Large	#6 / 392159	B7MMR
7MM REM MAG	0.284	546326	I	046327	044133	—	—	046044	#5 / 390545	#5 / 392605	Lg Rfl / 095316	—	#7 / 390949	Large	#6 / 392159	A7MMR
7MM WSM	0.284	546327	I	046451	044108	—	—	046056	#35 / 390575	#35 / 392635	Lg Rfl / 095316	—	#7 / 390949	Large	#6 / 392159	B7W5
7MM WBV MAG	0.284	546330	III	046331	044133	—	—	046044	#5 / 390545	#5 / 392605	Lg Rfl / 095316	—	#7 / 390949	Large	#6 / 392159	B7MMW
28 NOSLER	0.284	546329	III	046330	044133	—	—	046056	#5 / 390545	#5 / 392605	Lg Rfl / 095316	—	#7 / 390949	Large	#6 / 392159	B28N
7MM STW	0.284	546440	IV	—	—	—	—	046044	#5 / 390545	#5 / 392605	Lg Rfl / 095316	—	#7 / 390949	Large	#6 / 392159	—
7MM REM ULTRA MAG	0.284	546307	III	046454	044133	—	—	046056	#5 / 390545	#5 / 392605	Lg Rfl / 095316	—	#7 / 390949	Large	#6 / 392159	B7MM
7.35 CARCANO	0.300	546332	IV	—	—	—	—	—	#21 / 390561	— / —	Lg Rfl / 095316	—	#8 / 390950	Large	#7 / 392160	—
30 CARBINE	0.308	546503	II	046504	044142	044505	—	—	#22 / 390562	#22 / 392622	Sm Rfl / 095314	—	#9 / 390951	Small	#7 / 392160	—
30 REM	0.308	—	—	—	—	—	—	046050	#12 / 390552	#12 / 392612	Lg Rfl / 095316	095345	#9 / 390951	Large	#7 / 392160	—
300 BLACKOUT	0.308	546349	I	046459	044165	—	—	—	#16 / 390556	#16 / 392616	Sm Rfl / 095314	—	#9 / 390951	Small	#7 / 392160	A300A
300 HAM'R	0.308	546343	IV	—	—	—	—	—	#16 / 390556	#16 / 392616	Sm Rfl / 095314	—	#9 / 390951	Small	#7 / 392160	—
30 HERRETT	0.308	546334	IV	—	—	—	—	046050	#2 / 390542	#2 / 392602	Lg Rfl / 095316	—	#9 / 390951	Large	#7 / 392160	—
30-30 WIN	0.308	546342	I	046343	044111	—	—	046050	#2 / 390542	#2 / 392602	Lg Rfl / 095316	095345	#9 / 390951	Large	#7 / 392160	A3030
30-30 ACKLEY IMP	0.308	546345	IV	—	—	—	—	046050	#2 / 390542	#2 / 392602	Lg Rfl / 095316	095345	#9 / 390951	Large	#7 / 392160	—
303 SAVAGE	0.308	546354	IV	—	—	—	—	046050	#33 / 390573	— / —	Lg Rfl / 095316	095345	#9 / 390951	Large	#7 / 392160	—
300 SAVAGE	0.308	546348	III	046349	044111	—	—	046050	#1 / 390541	#1 / 392601	Lg Rfl / 095316	095345	#9 / 390951	Large	#7 / 392160	B300S
30 MERRILL	0.308	546338	IV	—	—	—	—	046050	#4 / 390544	#4 / 392604	Lg Rfl / 095316	095345	#9 / 390951	Large	#7 / 392160	—
307 WIN	0.308	546358	I	046359	044111	—	—	046045	#33 / 390573	— / —	Lg Rfl / 095316	095345	#9 / 390951	Large	#7 / 392160	—

*Discontinued SKUs with limited inventory.

APPENDIX A

APPENDIX A

RIFLE CARTRIDGE	Bullet Diameter (Inches)	Die Set	Die Series	Full- Length Size Die	Seating Die	Expander Die	Taper Crimp Die Only	Neck Size Die	Shell Holder # / Item No.	Shell Plate # / Item No.	Case Feeder Plate Size / Item No.	Bullet Feeder Die	Trimmer Pilot # / Item No.	Primer Punch	Bullet Puller Collet # / Item No.	Modified Case
308 MARLIN EXP	0.308	546357	III	046358	044111	—	—	046045	#27 / 390567	#27 / 392627*	Lg Rfl / 095316	095345	#9 / 390951	Large	#7 / 392160	A308ME
7.5 SWISS (7.5X55)	0.308	546360	III	046361	044111	—	—	046045	#2 / 390542	#2 / 392602	Lg Rfl / 095316	095345	#9 / 390951	Large	#7 / 392160	—
7.5 SWISS K31	0.308	546361	III	046362	044111	—	—	046045	#2 / 390542	#2 / 392602	Lg Rfl / 095316	095345	#9 / 390951	Large	#7 / 392160	—
308 WIN	0.308	546358	I	046359	044111	—	—	046045	#1 / 390541	#1 / 392601	Lg Rfl / 095316	095345	#9 / 390951	Large	#7 / 392160	A308
7.62X54R	0.308	546362	III	046363	044111	—	—	046050	#23 / 390563	#23 / 392623	Lg Rfl / 095316	095345	#9 / 390951	Large	#7 / 392160	—
30-40 KRAG	0.308	546344	IV	—	—	—	—	046045	#11 / 390551	#11 / 392611	Lg Rfl / 095316	095345	#9 / 390951	Large	#7 / 392160	—
30 TC	0.308	546335	III	046336	044111	—	—	046045	#1 / 390541	#1 / 392601	Lg Rfl / 095316	095345	#9 / 390951	Large	#7 / 392160	A307C*
30-06 SPRG	0.308	546340	I	046341	044112	—	—	046045	#1 / 390541	#1 / 392601	Lg Rfl / 095316	095345	#9 / 390951	Large	#7 / 392160	A3006
30-06 ACKLEY IMP	0.308	546341	IV	—	—	—	—	046045	#1 / 390541	#1 / 392601	Lg Rfl / 095316	095345	#9 / 390951	Large	#7 / 392160	—
300 H&H MAG	0.308	546346	IV	—	—	—	—	046045	#5 / 390545	#5 / 392605	Lg Rfl / 095316	095345	#9 / 390951	Large	#7 / 392160	A300H
300 OLYMPIC	0.308	546355	IV	—	—	—	—	—	#35 / 390575	#35 / 392635	Lg Rfl / 095316	—	#9 / 390951	Large	#7 / 392160	—
300 REM SA ULTRA MAG	0.308	546347	III	046455	044160	—	—	046057	#5 / 390545	#5 / 392605	Lg Rfl / 095316	095345	#9 / 390951	Large	#7 / 392160	B300R
308 NORMA MAG	0.308	546356	IV	—	—	—	—	046045	#5 / 390545	#5 / 392605	Lg Rfl / 095316	095345	#9 / 390951	Large	#7 / 392160	—
300 RCM	0.308	546353	III	046592	044111	—	—	046057	#5 / 390545	#5 / 392605	Lg Rfl / 095316	095345	#9 / 390951	Large	#7 / 392160	A300R
300 WSM	0.308	546369	I	046453	044160	—	—	046057	#35 / 390575	#35 / 392635	Lg Rfl / 095316	095345	#9 / 390951	Large	#7 / 392160	B300W
300 WIN MAG	0.308	546352	I	046353	044112	—	—	046045	#5 / 390545	#5 / 392605	Lg Rfl / 095316	095345	#9 / 390951	Large	#7 / 392160	A300M
300 WBY MAG	0.308	546350	I	046351	044112	—	—	046045	#5 / 390545	#5 / 392605	Lg Rfl / 095316	095345	#9 / 390951	Large	#7 / 392160	A300W
30 NOSLER	0.308	546337	IV	—	—	—	—	046057	#5 / 390545	#5 / 392605	Lg Rfl / 095316	095345	#9 / 390951	Large	#7 / 392160	B30N
300 PRC	0.308	546351	I	046334	044157	—	—	046057	#5 / 390545	#5 / 392605	Lg Rfl / 095316	095345	#9 / 390951	Large	#7 / 392160	B300P
300 REM ULTRA MAG	0.308	546365	III	046447	044159	—	—	046057	#5 / 390545	#5 / 392605	Lg Rfl / 095316	095345	#9 / 390951	Large	#7 / 392160	B300
30-378 WBY MAG	0.308	546419	IV	—	—	—	—	046057	#14 / 390554	#14 / 392614	Lg Rfl / 095316	095345	#9 / 390951	Large	#7 / 392160	C30378
7.62X39	0.308	546424	I	046425	044126	—	—	—	#6 / 390546	#6 / 392606	Sm Rfl / 095314	—	#9 / 390951	Large	#7 / 392160	A762
32-20 WIN	0.312	546364	III	046365	044113	—	—	—	#7 / 390547	#7 / 392607	Sm Rfl / 095314	—	#9 / 390951	Small	#7 / 392160	—
7.65 BELG	0.312	546368	III	046369	044114	—	—	—	#24 / 390564	— / —	Lg Rfl / 095316	—	#10 / 390952	Large	#7 / 392160	—
303 BRITISH	0.312	546366	III	046367	044114	—	—	—	#11 / 390551	#11 / 392611	Lg Rfl / 095316	—	#10 / 390952	Large	#7 / 392160	A303
7.7 JAP	0.312	546370	III	046371	044114	—	—	—	#1 / 390541	#1 / 392601	Lg Rfl / 095316	—	#10 / 390952	Large	#7 / 392160	—
32-40 WIN	0.321	546374	IV	—	—	—	—	—	#2 / 390542	#2 / 392602	Lg Rfl / 095316	—	#11 / 390953	Large	#8 / 392161	—
32 WIN SPL	0.321	546372	IV	—	—	—	—	—	#2 / 390542	#2 / 392602	Lg Rfl / 095316	—	#11 / 390953	Large	#8 / 392161	A32
32 REM	0.321	—	—	—	—	—	—	—	#12 / 390552	#12 / 392612	Lg Rfl / 095316	—	#12 / 390954	Large	#8 / 392161	—
8.15X46R	0.321	546386	IV	—	—	—	—	—	#2 / 390542	#2 / 392602	Lg Rfl / 095316	—	#11 / 390953	Large	#8 / 392161	—
7.92X33 KURZ	0.323	546375	III	046376	044137	—	—	—	#1 / 390541	#1 / 392601	Sm Rfl / 095314	—	#11 / 390953	Large	#8 / 392161	—
8X57	0.323	546382	III	046383	044116	—	—	—	#1 / 390541	#1 / 392601	Lg Rfl / 095316	—	#11 / 390953	Large	#8 / 392161	ABX57
8X57 JRS	0.323	546382	III	046383	044116	—	—	—	#13 / 390553	#13 / 392613*	Lg Rfl / 095316	—	#11 / 390953	Large	#8 / 392161	—
8X57 JS	0.323	546382	III	046383	044116	—	—	—	#1 / 390541	#1 / 392601	Lg Rfl / 095316	—	#11 / 390953	Large	#8 / 392161	ABX57
8X60S	0.323	546376	III	046377	044116	—	—	—	#1 / 390541	#1 / 392601	Lg Rfl / 095316	—	#11 / 390953	Large	#8 / 392161	—
325 WSM	0.323	546387	IV	—	—	—	—	—	#35 / 390575	#35 / 392635	Lg Rfl / 095316	—	#11 / 390953	Large	#8 / 392161	—
8X68S	0.323	546378	IV	—	—	—	—	—	#30 / 390570	#30 / 392630	Lg Rfl / 095316	—	#11 / 390953	Large	#8 / 392161	—

APPENDIX A

RIFLE CARTRIDGE	Bullet Diameter (Inches)	Die Set	Die Series	Full-Length Size Die	Seating Die	Expander Die	Taper Crimp Die Only	Neck Size Die	Shell Holder # / Item No.	Shell Plate # / Item No.	Case Feeder / Plate Size / Item No.	Bullet Feeder / Die	Trimmer Pilot # / Item No.	Primer Punch	Bullet Collet # / Item No.	Modified Case
8MM REM MAG	0.323	546384	IV	—	—	—	—	—	#5 / 390545	#5 / 392605	Lg Rfl / 095316	—	#11 / 390953	Large	#8 / 392161	A8MM
8X56 HUNGARIAN-WAANN	0.329	546385	IV	—	—	—	—	—	#47 / 390603	— / —	Lg Rfl / 095316	—	#11 / 390953	Large	#8 / 392161	—
338 FEDERAL	0.338	546397	III	046595	044131	—	—	046058	#1 / 390541	#1 / 392601	Lg Rfl / 095316	—	#13 / 390955	Large	#9 / 392162	—
338 MARLIN EXP	0.338	546359	III	046597	044131	—	—	046058	#52 / 390607	#52 / 392652*	Lg Rfl / 095316	—	#13 / 390955	Large	#9 / 392162	A338M*
338 RCIM	0.338	546399	III	046594	044131	—	—	046058	#5 / 390545	#5 / 392605	Lg Rfl / 095316	—	#13 / 390955	Large	#9 / 392162	A338R
338 WIN MAG	0.338	546390	I	046391	044117	—	—	046058	#5 / 390545	#5 / 392605	Lg Rfl / 095316	—	#13 / 390955	Large	#9 / 392162	A338
33 NOSLER	0.338	546381	IV	—	—	—	—	046058	#5 / 390545	#5 / 392605	Lg Rfl / 095316	—	#13 / 390955	Large	#9 / 392162	B33N
338 NORMA MAG	0.338	—	—	—	—	—	—	046058	#43 / 390583	— / —	Lg Rfl / 095316	—	#13 / 390955	Large	#9 / 392162	—
340 WBY MAG	0.338	546392	IV	—	—	—	—	046058	#5 / 390545	#5 / 392605	Lg Rfl / 095316	—	#13 / 390955	Large	#9 / 392162	A340
338 REM ULTRA MAG	0.338	546389	III	046446	044117	—	—	046058	#5 / 390545	#5 / 392605	Lg Rfl / 095316	—	#13 / 390955	Large	#9 / 392162	B338
338 LAPUA MAG	0.338	546393	III	046593	044117	—	—	046058	#43 / 390583	— / —	Lg Rfl / 095316	—	#13 / 390955	Large	#9 / 392162	C338L
338-378 WBY MAG	0.338	546391	IV	—	—	—	—	046058	#14 / 390554	#14 / 392614	Lg Rfl / 095316	—	#13 / 390955	Large	#9 / 392162	—
348 WIN	0.348	546394	IV	—	—	—	—	—	#25 / 390545	#25 / 392625*	Lg Rfl / 095316	—	#14 / 390956	Large	#9 / 392162	—
350 LEGEND	0.355	546401	V	046396	044125	045507	045800	—	#16 / 390556	#16 / 392616	Sm Rfl / 095314	—	#15 / 390957	Small	#9 / 392162	A350L
35 REM	0.358	546398	III	046399	044130	—	—	—	#26 / 390566	— / —	Lg Rfl / 095316	—	#15 / 390957	Large	#9 / 392162	A35R
356 WIN	0.358	—	—	—	—	—	—	046046	#33 / 390573	— / —	Lg Rfl / 095316	—	#15 / 390957	Large	#9 / 392162	—
358 WIN	0.358	546408	IV	—	—	—	—	046046	#1 / 390541	#1 / 392601	Lg Rfl / 095316	—	#15 / 390957	Large	#9 / 392162	B358
350 REM MAG	0.358	546402	IV	—	—	—	—	—	#5 / 390545	#5 / 392605	Lg Rfl / 095316	—	#15 / 390957	Large	#9 / 392162	A350
35 WHELEEN	0.358	546400	III	046401	044119	—	—	046046	#1 / 390541	#1 / 392601	Lg Rfl / 095316	—	#15 / 390957	Large	#9 / 392162	A35
358 NORMA MAG	0.358	546406	IV	—	—	—	—	046046	#5 / 390545	#5 / 392605	Lg Rfl / 095316	—	#15 / 390957	Large	#9 / 392162	—
9.3X57	0.366	546410	III	046411	044120	—	—	—	#1 / 390541	#1 / 392601	Lg Rfl / 095316	—	#20 / 390962	Large	#9 / 392162	—
9.3X62	0.366	546412	III	046413	044120	—	—	—	#1 / 390541	#1 / 392601	Lg Rfl / 095316	—	#20 / 390962	Large	#9 / 392162	A9362
9.3X74R	0.366	546414	III	046415	044120	—	—	—	#13 / 390553	#13 / 392613*	Lg Rfl / 095316	—	#20 / 390962	Large	#9 / 392162	C9374
38-55 WIN	0.375	546537	IV	—	—	—	—	—	#2 / 390542	#2 / 392602	Lg Rfl / 095316	—	#16 / 390958	Large	#10 / 392163	—
375 WIN	0.375	546530	IV	—	—	—	—	—	#2 / 390542	#2 / 392602	Lg Rfl / 095316	—	#16 / 390958	Large	#10 / 392163	—
376 STEYR	0.375	546417	IV	—	—	—	—	—	#15 / 390555	#15 / 392615*	Lg Rfl / 095316	—	#16 / 390958	Large	#10 / 392163	—
375 FL MAG NITRO EXP	0.375	546449	IV	—	—	—	—	—	#43 / 390583	— / —	Lg Rfl / 095316	—	#16 / 390958	Large	#10 / 392163	—
375 RUGER	0.375	546415	I	046418	044121	—	—	—	#5 / 390545	#5 / 392605	Lg Rfl / 095316	—	#16 / 390958	Large	#10 / 392163	C375R
375 H&H MAG	0.375	546416	III	046417	044121	—	—	—	#5 / 390545	#5 / 392605	Lg Rfl / 095316	—	#16 / 390958	Large	#10 / 392163	A375
375 REM ULTRA MAG	0.375	546450	IV	—	—	—	—	—	#5 / 390545	#5 / 392605	Lg Rfl / 095316	—	#16 / 390958	Large	#10 / 392163	—
378 WBY MAG	0.375	546418	IV	—	—	—	—	—	#14 / 390554	#14 / 392614	Lg Rfl / 095316	—	#16 / 390958	Large	#10 / 392163	B378*
450-400 NITRO EXP 3"	0.410	546421	IV	—	—	—	—	—	#25 / 390565	#25 / 392625*	Lg Rfl / 095316	—	#17 / 390959	Large	#11 / 392164	C450*
405 WIN	0.411	546425	II	046456	044162	044571	—	—	#42 / 390582	— / —	Lg Rfl / 095316	—	#17 / 390959	Large	#11 / 392164	C405
10.3X60R SWISS	0.415	546420	IV	—	—	—	—	—	#25 / 390565	#25 / 392625*	Lg Rfl / 095316	—	#17 / 390959	Large	#11 / 392164	—
416 RUGER	0.416	546429	IV	—	—	—	—	—	#5 / 390545	#5 / 392605	Lg Rfl / 095316	—	#17 / 390959	Large	#11 / 392164	C416RG*
416 REM MAG	0.416	546426	IV	—	—	—	—	—	#5 / 390545	#5 / 392605	Lg Rfl / 095316	—	#17 / 390959	Large	#11 / 392164	A416*
416 RIGBY	0.416	546428	IV	—	—	—	—	—	#38 / 390578	— / —	Lg Rfl / 095316	—	#17 / 390959	Large	#11 / 392164	C416R

*Discontinued SKUs with limited inventory.

APPENDIX A

APPENDIX A

RIFLE CARTRIDGE		Bullet Diameter (inches)	Die Set	Die Series	Full-Length Size Die	Seating Die	Expander Die	Taper Crimp Die Only	Neck Size Die	Shell Holder # / Item No.	Shell Plate # / Item No.	Case Feeder Plate Size / Item No.	Bullet Feeder Die	Trimmer Pilot # / Item No.	Primer Punch	Bullet Collet # / Item No.	Modified Case
416	WBV MAG	0.416	546430	IV	—	—	—	—	—	#14 / 390554	#14 / 392614	Lg Rfl / 095316	—	#17 / 390959	Large	#11 / 392164	—
404	JEFFERY	0.423	546423	IV	—	—	—	—	—	#53 / 390608	— / —	Lg Rfl / 095316	—	#17 / 390959	Large	#12 / 392165	—
444	MARLIN	0.430	546551	II	046552	044149	044553	—	—	#27 / 390567	#27 / 392627*	Lg Rfl / 095316	—	#18 / 390960	Large	#12 / 392165	—
450	BUSHMASTER	0.452	546452	V	046422	044721	044550	044176	—	#1 / 390541	#1 / 392601	Lg Rfl / 095316	—	#19 / 390961	Large	#13 / 392166	A450B
458	SOCOM	0.458	546464	III	046424	044190	—	—	—	#1 / 390541	#1 / 392601	Lg Rfl / 095316	—	#19 / 390961	Small	#13 / 392166	—
45-70	GOVT	0.458	546566	II	046567	044152	044568	—	—	#14 / 390554	#14 / 392614	Lg Rfl / 095316	—	#19 / 390961	Large	#13 / 392166	A4570
450	MARLIN	0.458	546553	II	046587	044152	044568	—	—	#5 / 390545	#5 / 392605	Lg Rfl / 095316	—	#19 / 390961	Large	#13 / 392166	—
450	NITRO EXP 3¼"	0.458	546433	IV	—	—	—	—	—	#54 / 390609	— / —	N/A	—	#19 / 390961	Large	#13 / 392166	C450NE*
458	WIN MAG	0.458	546569	II	046570	044153	044568	—	—	#5 / 390545	#5 / 392605	Lg Rfl / 095316	—	#19 / 390961	Large	#13 / 392166	C458W
458	LOTT	0.458	546465	II	046457	044204	044572	—	—	#5 / 390545	#5 / 392605	Lg Rfl / 095316	—	#19 / 390961	Large	#13 / 392166	C458L
460	WBV MAG	0.458	546422	IV	—	—	—	—	—	#14 / 390554	#14 / 392614	Lg Rfl / 095316	—	#19 / 390961	Large	#13 / 392166	—
470	NITRO EXP 3¼"	0.474	546434	IV	—	—	—	—	—	#55 / 390610	— / —	N/A	—	#23 / 390939	Large	— / —	C470N*
50-70	GOVT	0.510	546462	IV	—	—	—	—	—	— / —	— / —	Lg Rfl / 095316	—	#50 / 390937	Large	— / —	—
50	ALASKAN	0.510	546586	IV	—	—	—	—	—	#25 / 390565	#25 / 392625*	Lg Rfl / 095316	—	#50 / 390937	Large	— / —	—
500	NITRO EXP 3"	0.510	546435	IV	—	—	—	—	—	#55 / 390610	— / —	N/A	—	#50 / 390937	Large	— / —	C500N*

PISTOL CARTRIDGE		Bullet Diameter (inches)	Die Set	Die Series	Full-Length Size Die	Seating Die	Expander Die	Taper Crimp Seater Die	Taper Crimp Die Only	Shell Holder # / Item No.	Shell Plate # / Item No.	Case Feeder Plate Size / Item No.	Bullet Feeder Die	Trimmer Pilot # / Item No.	Primer Punch
22	TCM	0.224	546215	IV	—	—	—	—	—	#16 / 390556	#16 / 392616	— / —	—	#1 / 390943	Small
25	AUTO	0.251	—	—	—	—	—	—	—	#37 / 390577	— / —	Sm Pstl / 095310	N/A	#4 / 390946	Small
30	LUGER	0.308	546336	IV	—	—	—	—	—	#8 / 390548	#8 / 392608	Sm Pstl / 095310	N/A	#9 / 390951	Small
30	MAUSER	0.309	—	—	—	—	—	—	—	#8 / 390548	#8 / 392608	Sm Pstl / 095310	N/A	#9 / 390951	Small
32	AUTO	0.311	546506	III	046507	044113	044508	—	—	#22 / 390562	#22 / 392622	Sm Pstl / 095310	N/A	#10 / 390952	Small
32	S&W LONG	0.312	546509	III	046510	044143	044511	—	—	#36 / 390576	#36 / 392636	Sm Pstl / 095310	N/A	#10 / 390952	Small
32	H&R MAG	0.312	546509	III	046510	044143	044511	—	—	#36 / 390576	#36 / 392636	Sm Pstl / 095310	N/A	#10 / 390952	Small
327	FEDERAL MAG	0.312	546509	III	046510	044143	044511	—	—	#36 / 390576	#36 / 392636	Sm Pstl / 095310	N/A	#10 / 390952	Small
7.5	SWISS ORDNANCE	0.312	546504	IV	—	—	—	—	—	#48 / 390604	— / —	— / —	N/A	#10 / 390952	Small
8MM	LEBEL REVOLVER	0.326	546510	IV	—	—	—	—	—	#48 / 390604	— / —	— / —	N/A	#11 / 390953	Large
380	AUTO	0.355	546518	II	046519	044144	044517	—	044170	#16 / 390556	#16 / 392616	Sm Pstl / 095310	095330	#15 / 390957	Small
9MM	LUGER TAPER CRIMP	0.355	546516	II	046516	044177	044517	044177	—	#8 / 390548	#8 / 392608	Sm Pstl / 095310	095330	#15 / 390957	Small
9MM	LUGER	0.355	546515	II	046516	044144	044517	—	044170	#8 / 390548	#8 / 392608	Sm Pstl / 095310	095330	#15 / 390957	Small
9X21	TAPER CRIMP	0.355	546516	II	046516	044177	044517	044177	—	#8 / 390548	#8 / 392608	Sm Pstl / 095310	095330	#15 / 390957	Small
9X21		0.355	546515	II	046516	044144	044517	—	044170	#8 / 390548	#8 / 392608	Sm Pstl / 095310	095330	#15 / 390957	Small
38	SUPER AUTO	0.355	546524	II	046525	044144	044526	—	—	#8 / 390548	#8 / 392608	Sm Pstl / 095310	N/A	#15 / 390957	Small
357	SIG	0.355	546575	II	046576	044150	044577	—	—	#10 / 390550	#10 / 392610	Sm Pstl / 095310	N/A	#15 / 390957	Small
9X23	WIN	0.355	546532	IV	—	—	—	—	—	#8 / 390548	#8 / 392608	Sm Pstl / 095310	N/A	#15 / 390957	Small
38	SPL	0.357	546527	II	046528	044145	044523	—	—	#6 / 390546	#6 / 392606	Lg Pstl / 095312	095331	#15 / 390957	Small

APPENDIX A

PISTOL CARTRIDGE	Bullet Diameter (inches)	Die Set	Die Series	Full-Length Size Die	Seating Die	Expander Die	Taper Crimp Seater Die	Taper Crimp Die Only	Shell Holder # / Item No.	Shell Plate # / Item No.	Case Feeder Plate Size / Item No.	Bullet Feeder Die	Trimmer Pilot # / Item No.	Primer Punch
	COWBOY 38 SPL	0.357	546528	III	046528	044169	044591	—	—	#6 / 390546	#6 / 392606	Lg Pst / 095312	N/A	#15 / 390957
357 MAG	0.357	546527	II	046528	044145	044523	—	—	#6 / 390546	#6 / 392606	Lg Pst / 095312	095331	#15 / 390957	Small
COWBOY 357 MAG	0.357	546528	III	046528	044169	044591	—	—	#6 / 390546	#6 / 392606	Lg Pst / 095312	N/A	#15 / 390957	Small
357 REM MAX	0.357	546527	II	046528	044145	044523	—	—	#6 / 390546	#6 / 392606	Lg Pst / 095312	095331	#15 / 390957	Small
COWBOY 357 REM MAX	0.357	546528	III	046528	044169	044591	—	—	#6 / 390546	#6 / 392606	Lg Pst / 095312	N/A	#15 / 390957	Small
38 S&W	0.357	546521	IV	—	—	—	—	—	#28 / 390568	#28 / 392628*	Lg Pst / 095312	N/A	#15 / 390957	Large
357 HERRETT	0.357	546396	IV	—	—	—	—	—	#2 / 390542	#2 / 392602	Lg Pst / 095312	N/A	#15 / 390957	Large
9X18 MAKAROV	0.364	546512	II	046513	044154	044514	—	—	#8 / 390548	#8 / 392608	Sm Pst / 095310	N/A	#15 / 390957	Small
40 S&W TAPER CRIMP	0.400	546534	II	046534	044178	044535	044178	—	#10 / 390550	#10 / 392610	Lg Pst / 095312	095332	#21 / 390941	Small
40 S&W	0.400	546533	II	046534	044146	044535	—	044171	#10 / 390550	#10 / 392610	Lg Pst / 095312	095332	#21 / 390941	Small
10MM AUTO TAPER CRIMP	0.400	546534	II	046534	044178	044535	044178	—	#10 / 390550	#10 / 392610	Lg Pst / 095312	095332	#21 / 390941	Large
10MM AUTO	0.400	546533	II	046534	044146	044535	—	044171	#10 / 390550	#10 / 392610	Lg Pst / 095312	095332	#21 / 390941	Large
41 AE	0.410	546539	III	046540	044147	044541	—	—	#8 / 390548	#8 / 392608	Lg Pst / 095312	N/A	#17 / 390959	Small
41 REM MAG	0.410	546539	III	046540	044147	044541	—	—	#29 / 390569	#29 / 392629	Lg Pst / 095312	N/A	#17 / 390959	Large
COWBOY 44-40 WIN	0.429	546543	III	046460	044166	044593	—	—	#9 / 390549	#9 / 392609	Lg Pst / 095312	N/A	#18 / 390960	Large
44 SPL	0.430	546548	II	046549	044148	044544	—	—	#30 / 390570	#30 / 392630	Lg Pst / 095312	095333	#18 / 390960	Large
COWBOY 44 SPL	0.430	546549	III	046549	044166	044592	—	—	#30 / 390570	#30 / 392630	Lg Pst / 095312	N/A	#18 / 390960	Large
44 REM MAG	0.430	546548	II	046549	044148	044544	—	—	#30 / 390570	#30 / 392630	Lg Pst / 095312	095333	#18 / 390960	Large
44 AUTO MAG	0.430	546545	IV	—	—	—	—	—	#1 / 390541	#1 / 392601	Lg Pst / 095312	095333	#18 / 390960	Large
445 SUPER MAG	0.430	—	—	—	—	—	—	—	#30 / 390570	#30 / 392630	Lg Pst / 095312	N/A	#18 / 390960	Large
45 AUTO TAPER CRIMP	0.451	546555	II	046555	044179	044556	044179	—	#45 / 390606	#45 / 392645	Lg Pst / 095312	095334	#19 / 390961	Large
45 AUTO	0.451	546554	II	046555	044151	044556	—	044172	#45 / 390606	#45 / 392645	Lg Pst / 095312	095334	#19 / 390961	Large
45 AUTO RIMMED	0.451	546554	II	046555	044151	044556	—	044172	#31 / 390571	— / —	Lg Pst / 095312	095334	#19 / 390961	Large
45 WIN MAG	0.451	546554	II	046555	044151	044556	—	044172	#1 / 390541	#1 / 392601	Lg Pst / 095312	095334	#19 / 390961	Large
45 S&W SCHOFIELD	0.452	546546	IV	—	—	—	—	—	#41 / 390581	— / —	Lg Pst / 095312	095334	#19 / 390961	Large
45 COLT	0.452	546582	II	046583	044151	044556	—	—	#32 / 390572	#32 / 392632	Lg Pst / 095312	095334	#19 / 390961	Large
COWBOY 45 COLT	0.452	546581	III	046583	044168	044594	—	—	#32 / 390572	#32 / 392632	Lg Pst / 095312	095334	#19 / 390961	Large
454 CASULL	0.452	546584	V	046584	044151	044556	—	044588	#32 / 390572	#32 / 392632	Lg Pst / 095312	095334	#19 / 390961	Small
460 S&W MAG	0.452	546583	V	046720	044721	044719	—	044722	#46 / 390602	#46 / 392646	Lg Rfl / 095316	095334	#19 / 390961	Large
455 WEBLEY	0.455	—	—	—	—	—	—	—	#51 / 390601	— / —	Lg Pst / 095312	N/A	#19 / 390961	Large
475 LINEBAUGH	0.475	546547	V	046585	044158	044586	—	044174	#14 / 390554	#14 / 392614	Lg Pst / 095312	N/A	#23 / 390939	Large
480 RUGER	0.475	546547	V	046585	044158	044586	—	044174	#14 / 390554	#14 / 392614	Lg Pst / 095312	N/A	#23 / 390939	Large
50 AE	0.500	546580	II	046581	044155	044582	—	—	#40 / 390580	#40 / 392640	Lg Rfl / 095316	N/A	#50 / 390937	Large
500 S&W MAG	0.500	546585	V	046699	044700	044701	—	044702	#44 / 390584	#44 / 392644	Lg Rfl / 095316	N/A	#50 / 390937	Large
500 LINEBAUGH	0.510	546587	IV	—	—	—	—	—	#25 / 390565	#25 / 392625*	Lg Rfl / 095316	N/A	#50 / 390937	Large

*Discontinued SKUs with limited inventory.

WARRANTY

All Hornady reloading tools and accessories are warranted against material defects and workmanship

This warranty is void if the product (1) has been damaged by accident or unreasonable use, neglect, improper service or other causes not arising out of defects in material or workmanship; or (2) has been altered or repairs have been made or attempted by other than authorized factory personnel; (3) is used commercially; or (4) has been altered or defaced in any way.

This warranty supersedes all other warranties for Hornady products either written or oral. No other warranty is expressed or implied.

PRODUCT REGISTRATION AND SERVICE

You must register your product to obtain Warranty Service. Complete the registration form at hornady.com/warranties.

TO RECEIVE WARRANTY SERVICE

To report a warranty claim, call Hornady® at 800-338-3220 to request a return authorization number. Returns will not be accepted without prior return authorization by Hornady®.



POST-WARRANTY SERVICE INFORMATION

For issues concerning service after the Limited Warranty expires, contact Hornady® at 800-338-3220.

PRODUCT SERIAL NUMBER AND REFERENCE INFORMATION

You must register your product in order to obtain warranty service. In the event you should need service for your product, please note the following information:

Serial Number _____

Date Purchased _____

Retailer _____

Hornady Manufacturing Company

P.O. Box 1848, Grand Island, NE 68802-1848
308-382-1390 • 800-338-3220 • Fax: 308-382-5761
hornady.com/contact