

ACCUFIRE

2.5-20X50 RIFLESCOPE

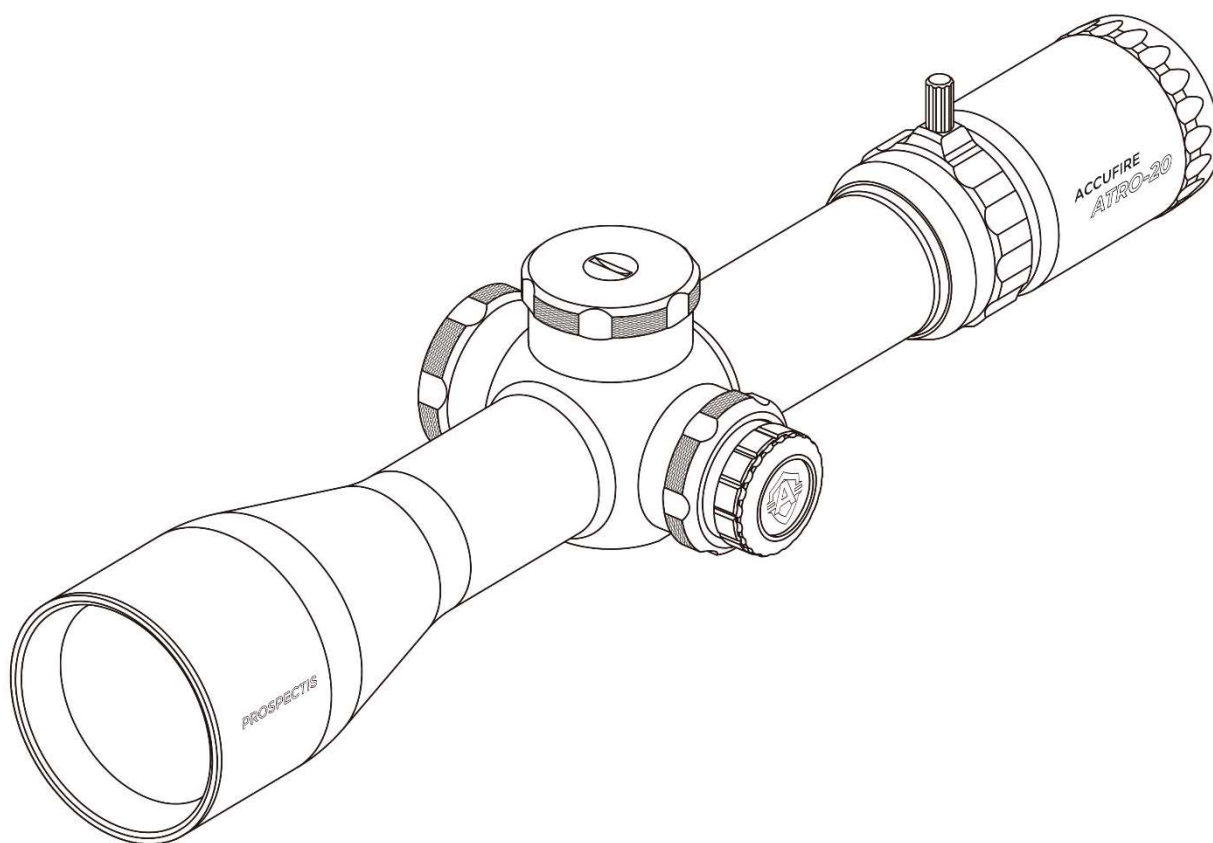

PRODUCT MANUAL

RIFLESCOPE

TUBE SIZE	34mm	LENGTH	352mm
EYE RELIEF	3.51 in.	WEIGHT	820g
FIELD OF VIEW AT LOWEST MAGNIFICATION	44.2ft/100yds	FRONT OR SECOND FOCAL	Front
FIELD OF VIEW AT HIGHEST MAGNIFICATION	6.4ft/100yds	LOCKING TURRET	Yes
ADJUSTMENT GRADUATION	0.1 mil	COATING	Accucoat
TRAVEL PER ROTATION	10 mils	ILLUMINATION	Yes
MAX ELEVATION ADJUST.	39.56mils	CAT TAIL	Yes
MAX WINDAGE ADJUST.	25mils	RECOIL RATING	1000G
PARALLAX SETTING	10yds to infinity		

2.5-20X50

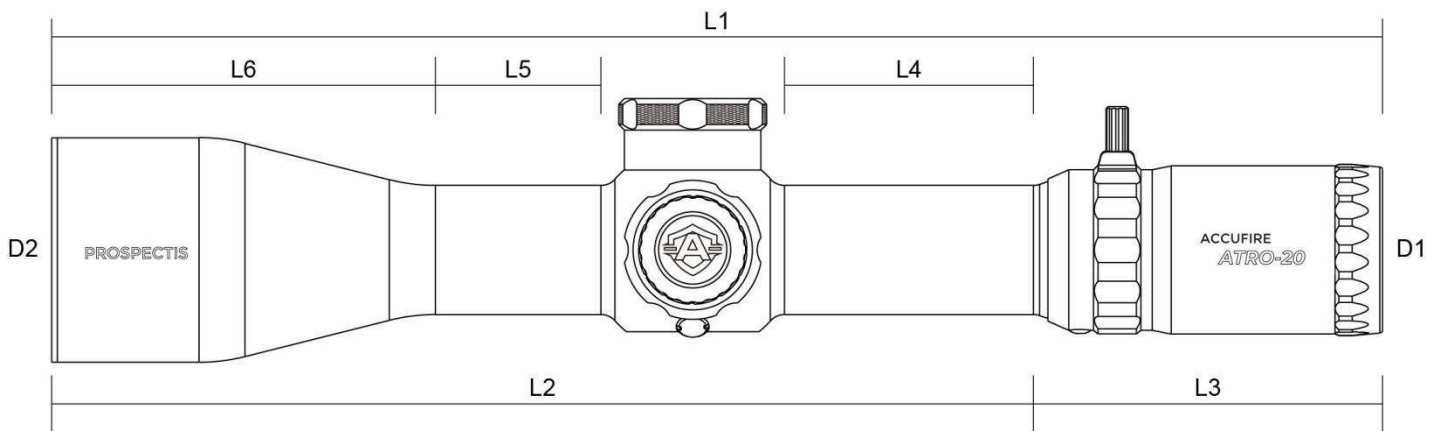

L1: 352

D1: 43.6

Unit:MM

L2: 258.9

D2: 59

L3: 92

L4: 65.7

L5: 43.7

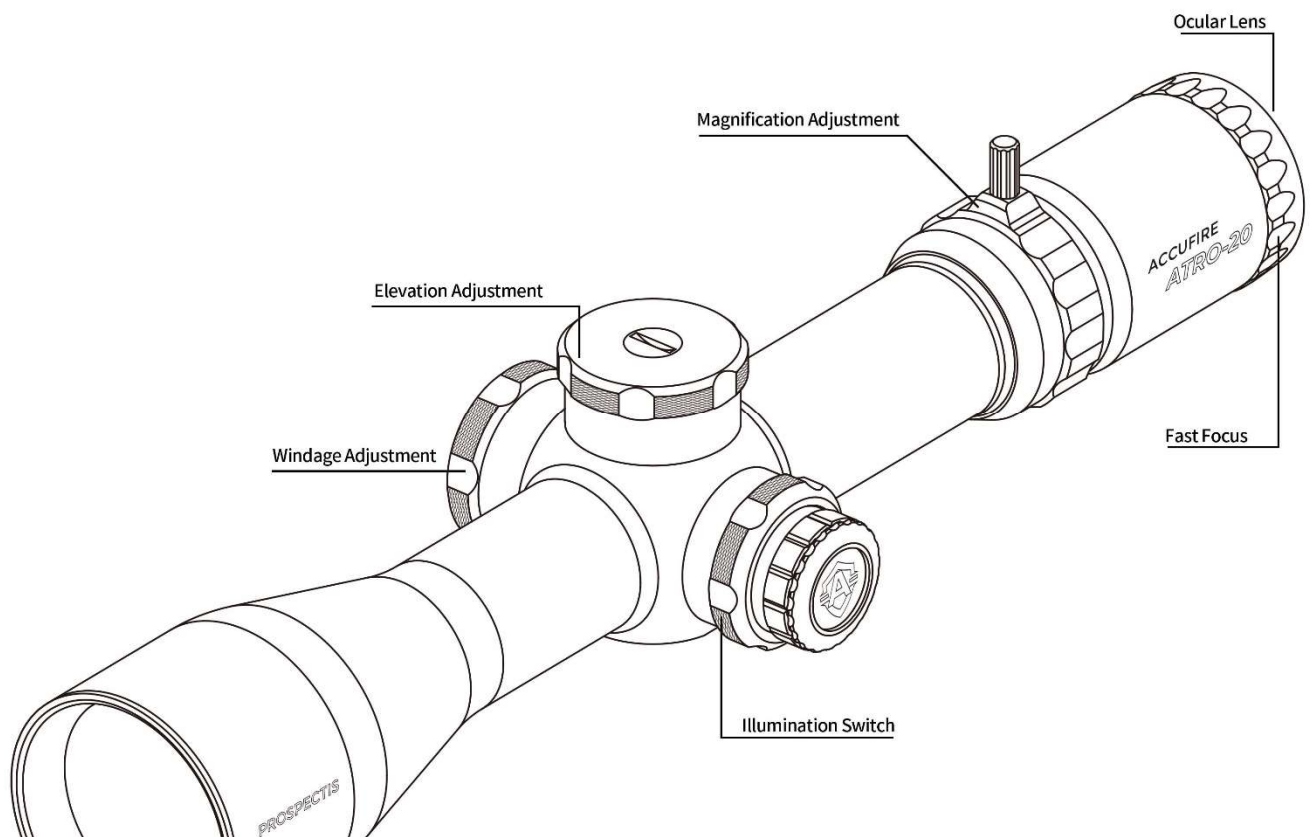

WARNING: *BEFORE HANDLING ANY FIREARM, ENSURE THAT THE FIREARM IS UNLOADED, CHAMBER CLEAR, AND POINTED AWAY FROM ANY UNINTENDED BACKDROP IN A SAFE DIRECTION.*

UNDERSTANDING THE RIFLESCOPE

Reticle Focal Plane

All riflescope reticles are either First Focal Plane (FFP) or Second Focal Plane (SFP), depending on the reticle's location within the riflescope. This riflescope features an FFP reticle with mil-radian value holds.

Ocular Focus

The ocular focus is essentially a one-time adjustment used to focus the reticle for maximum sharpness. This adjustment is slightly different for every shooter. A clearly focused reticle is a critical component for accurate

shooting.

Ocular Focus--Reticle Focus Adjustment

Your riflescope uses a fast-focus eyepiece designed to quickly and easily adjust the focus on the riflescope's reticle. To adjust the reticle focus:

1. Look through the riflescope at a blank white wall or up at the sky.
2. Turn focus knob fully outward (counterclockwise).
3. Slowly turn the eyepiece focus knob inward until the reticle image is as crisp as possible

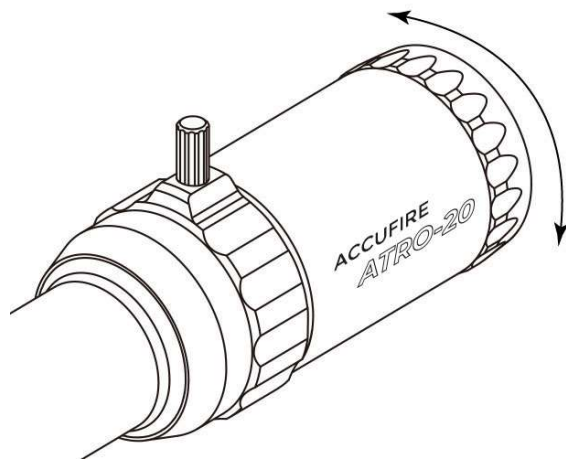

TIP: Make this adjustment by taking short, quick glances through the scope as your eye will try to compensate for an out-of-focus reticle.

WARNING: Looking directly at the sun through a riflescope, or any optical instrument, can cause severe and permanent damage to your eyesight.

Magnification

The magnification adjustment is used to change the riflescope's magnification level, or "power," adjusting from low to high magnification depending on the shooter's preference.

Magnification Adjustment

Rotate the magnification ring to the desired magnification

Throw Lever Installation

Thread in the included throw lever as shown until the throw lever is secured.

Arc Measurements

This scope uses mil-radian arc measurements.

Mil-radian (Mils) arc measurements are based on the concept of radial measurements of angle. Generally, one mil-radian equals 3.6 inches at 100 yards. Adjustments can be dialed into the cap at an adjustment of 0.1 m-rad per click.

Turrets

Use turrets to adjust the bullet's point-of-impact. There are two turrets on your riflescope. The turret on the top of the riflescope is the Elevation Turret and is used to adjust the point-of-impact up and down. The turret on the right-hand side of the riflescope is the Windage Turret and is used to adjust the point-of-impact left and right. Accufire riflescopes incorporate precision, finger adjustable Elevation and Windage Turrets with audible and tactile clicks. Some scope models may include Accufires ZRS knobs and locking functions to prevent accidental adjustments.

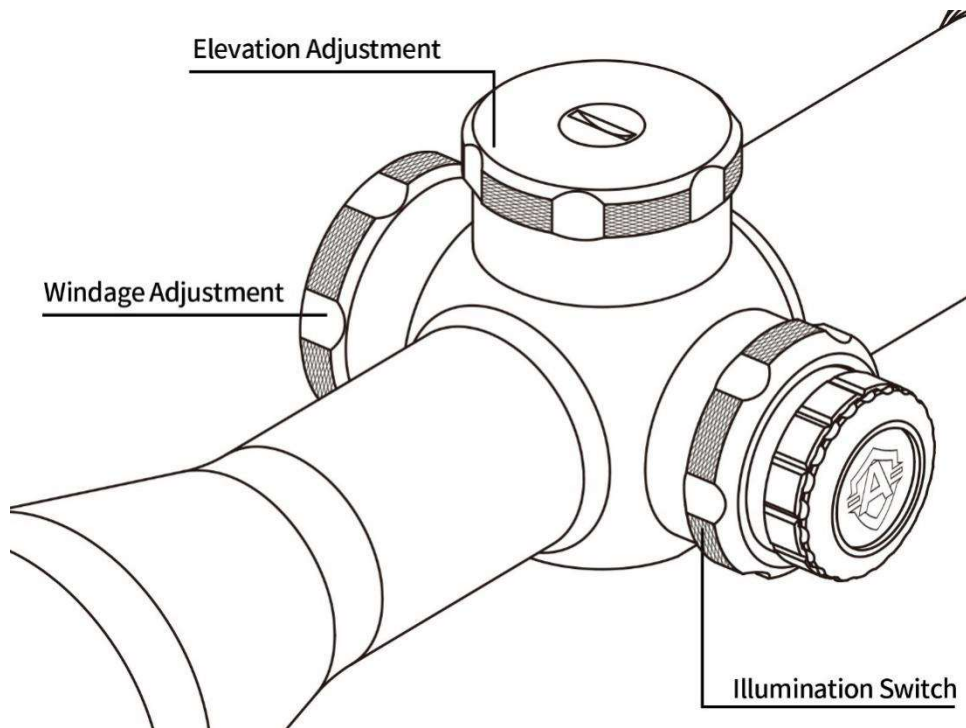

Turret Adjustments

Your riflescope features adjustable elevation and windage turret dials with audible and tactile clicks. Each click moves the bullet's point of impact 0.1 mils or approximately .33 inches at 100 yards.

To make turret adjustments and zero:

1. If your scope has locking turrets, unlock the turret by gently pulling the turret away from the scope. Otherwise just turn the turret.
2. Following the directional arrows, turn the dials in the direction you wish the bullets point of impact to go.
3. When finished adjusting impact, remove turret by using a small rounded flathead or coin to remove turret retention screw. Be careful not to lose the insert or O-ring under the retention screw.

4. Gently remove the turret cap completely off the erector without turning the turret and turn the turret to where the zero lines up with the scope's adjustment indicator line.

NOTE: If turret has a ZRS for zero retention, be sure to tighten ZRS indicator before replacing turrets.

5. Push the turret all the way down until the turret locks.

6. Replace the turret retention screw, insert, and O-ring. Hand tighten to snug.

NOTE: Accufire Tango scopes contain turret position indicators set with beads on 0 (one bead) and 5 (two beads) m-rad settings. Such indicators are designed to assist the shooter with quick adjustments without visual confirmation.

Image Sharpness—Parallax

Your scope comes equipped with an adjustable parallax from 50 yds-infinity.

Battery Installation/Replacement

To install/change the battery, unscrew the illumination dial's outer cap, Insert a new CR2032 battery positive terminal facing away from the scope. Replace cap.

Replacing the Battery:

1. Unscrew the outer cap.
2. Remove the CR2032 battery.
3. Replace with a new CR2032 battery with the positive terminal facing away from the scope.

Illumination Side Illumination Control

Your riflescope uses a variable intensity reticle illumination system to aid in low-light performance. A rotary dial is mounted on the left-hand side of the riflescope for easy access.

To activate/adjust the illumination, rotate the adjustment dial in either direction. The illumination dial allows for multiple levels of illumination intensity.

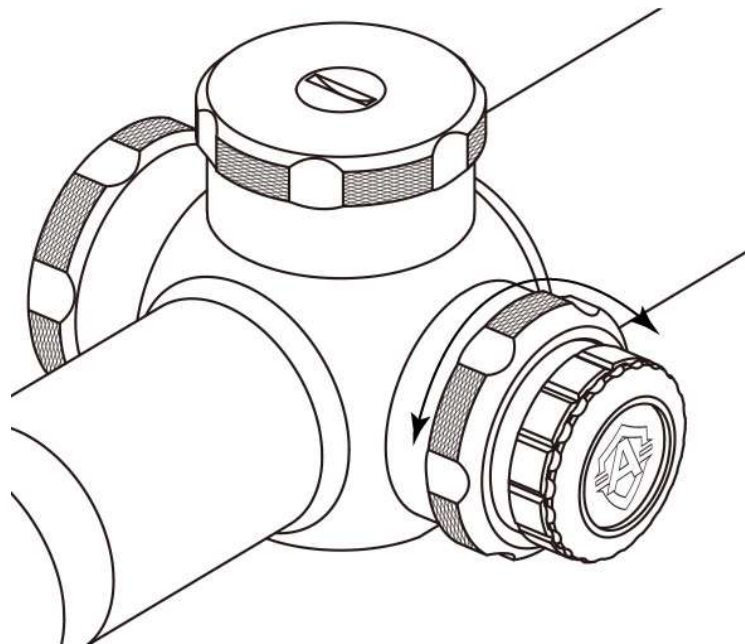

RIFLESCOPE MOUNTING

To get the best performance from your Accufire riflescope, proper mounting is essential. Although not difficult, you must follow the correct steps. Please follow the instructions below for the proper scope mounting procedure.

If you are unsure of your abilities, use the services of a qualified gunsmith.

Riflescope Mounting Checklist

- ✓ Level gun vise or a solid platform/rest for your rifle
- ✓ Scope rings
- ✓ Torque wrench
- ✓ Reticle leveling tool.

Recommendation: Use a Torque Wrench Mounting Kit, which comes with the complete set of bits needed to install Accufire scopes and rings!

Rings and Bases

Your Accufire riflescope features a 30mm or 34mm one piece tube. Be sure to select a base, and matching rings appropriate for your rifle, and mount according to the manufacturer's instructions.

Note: Accufire recommends not exceeding 18 in./lbs. (inch/pounds) of torque on the ring screws.

Eye Relief and Reticle Alignment

After installing the bottom ring halves on the mounting base, place the riflescope on the bottom ring halves and loosely install the upper ring halves. Before tightening the scope ring screws, adjust for maximum eye relief to avoid Injury from recoil:

1. Set the riflescope to its highest magnification.
2. Ensure the riflescope is centered in the rings.
3. While viewing through the riflescope in a normal shooting position, slowly slide the riflescope back toward your face. Pay attention to the field of view. Stop sliding the riflescope back as soon as you see the full field of view.
4. Without disturbing the front-back placement, rotate the riflescope until the vertical crosshair exactly matches the vertical axis of the rifle.

NOTE: Using a reticle leveling tool, a bubble level, or an adjustable set of feeler gauges placed between a one-piece base and the flat bottom of the riflescope's center section will help with this procedure.

5. After aligning the reticle, tighten and torque the ring screws down per the manufacturer's instructions. Use caution and do not overtighten.

Bore Sighting

Initial bore sighting will save time and money at the range. Do this by using

a mechanical or laser bore sight according to the manufacturer's instructions, or by removing the bolt and sighting through the barrel on some rifles. *BEFORE HANDLING ANY FIREARM, ENSURE THAT THE FIREARM IS UNLOADED, CHAMBER CLEAR, AND POINTED AWAY FROM ANY UNINTENDED BACKDROP IN A SAFE DIRECTION.*

To Visually Bore Sight a Rifle:

1. Place the rifle solidly on a rest and remove the bolt. Ensure the rifle is clear of any ammunition, including magazines, clips, and chambered rounds.
2. Sight through the bore at a target between 10-50 yards away.
3. Move the rifle and rest until the boresight laser is visually set on your intended backdrop in a safe direction.
4. With the boresight laser visible on the intended backdrop, make windage and elevation adjustments until the reticle crosshair is also centered over the laser.

Final Range Sight-In

After the riflescope has been bore-sighted, final sight-in should be done at the range using the exact ammunition you expect to use. Sight-in and zero the riflescope at the preferred distance. 100 yards is the most common zero distance, although you may prefer a 200-yard zero for other

applications.

1. Following all safe shooting practices, fire a three-shot group as precisely as possible.
2. Next, adjust the reticle to match the approximate center of the shot group, Be sure to read pages 6-7 prior to making adjustments.
3. Carefully fire another three-shot group and see if the bullet group is centered on the bullseye or point-of-aim. This procedure can be repeated as many times as necessary to achieve a perfect zero.

Indexing the Elevation and Windage Turrets

Accufire riflescopes feature Elevation and Windage Turrets that allow you to re-index the zero indicator after sight-in without disturbing your zero setting. Though not a required process, re-indexing the turrets allows you to quickly return to your original zero setting if you dial temporary corrections in the field.

To Index the Turrets

See turret adjustment page 6-7.

MAINTENANCE

Cleaning

The Accufire riflescope requires very little routine maintenance other than periodically cleaning the exterior lenses. The scope's exterior may be

cleaned by wiping with a lens cleaner. When cleaning the lenses, be sure to use products that are specifically designed for use on coated optical lenses. Abrasive chemicals can damage coatings and/or the lens.

- Be sure to blow away any dust or grit on the lenses prior to wiping the surfaces to prevent scratching lens.

Lubrication

All Accufire components are permanently lubricated, so no additional lubricant should be applied.

Note: Other than to remove the turret caps and battery cap, do not attempt to disassemble any components of the riflescope. Disassembling of riflescope may void warranty.

TROUBLESHOOTING

Please check the following items prior to returning a riflescope for service.

Sighting-In Problems

Many times, problems thought to be with the scope are actually mounting problems. Be sure the mounts are properly torqued to the rifle and the scope is secured so it does not twist or move in the rings. An insufficient windage or elevation adjustment range may indicate problems with the base mount, base mount holes drilled in the rifle's receiver, or barrel/receiver alignment.

Grouping Problems

There are many issues that can cause poor bullet grouping.

- Be sure that rings are correctly torqued to 18 in/lbs.
- Be sure that all screws on rifle' s action are properly tightened
- Be sure rifle barrel and action are clean and free of excessive oil or copper fouling.
- Maintain a good shooting technique and use a solid rest.
- Some rifles and ammunition don't work well together-try different ammunition and see if accuracy improves.

Common Problems

Point of Impact Changes Drastically After Turret Adjustment

- Verify that the ring screws are not over torqued or cambered. Ring screws should only be torqued to 18 in/lbs. Thread-lock (blue not red) may be optional. Over torqueing the ring screws may cause excess pressure on the tube which will cause problems when adjusting the reticle.

Point of Impact is Inconsistent

- Ensure the cantilever mount/rings are mounted only to the receiver. The cantilever mount/rings need to be mounted to one, solid surface (e.g. the action). Make sure that the forward connection of the cantilever mount,

or ring, is not mounted to the fore end of the rifle.

- Verify that the ring screws are not over torqued. Ring screws should only be torqued to 18 in/lbs. Over torquing the ring screws will cause excess pressure on the tube, which may cause problems when adjusting the reticle.

Insufficient Adjustment Ranges

- Check that you have the proper base and rings for your rifle and for your size. If you need assistance, contact a local gunsmith to be properly fitted to your rifle and scope.

- Once you have verified that you have the correct base and mounts, and that you have been properly fitted to your gun, make sure you followed the correct mounting procedure. See Riflescope Mounting section for this procedure.

Reticle Appears to Come In and Out of Focus

- Check and reset the ocular focus of the reticle for the shooter's eye. See Riflescope Adjustments section, Ocular Focus -Reticle Focus Adjustment.

Reticles

See reticle card.